

BRAKE SYSTEM

BR061-01

PRECAUTION

1. Care must be taken to replace each part properly as it could affect the performance of the brake system and result in a driving hazard. Replace the parts with parts have the same part number or equivalent.
2. It is very important to keep parts and the area clean when repairing the brake system.
3. If the vehicle is equipped with a mobile communication system, refer to the precautions in the IN section.

TROUBLESHOOTING

PROBLEM SYMPTOMS TABLE

BR062-01

Use the table below to help you find the cause of the problem. The numbers indicate the priority of the likely cause of the problem. Check each part in order. If necessary, replace these parts.

Symptom	Suspect Area	See page
Lower pedal or spongy pedal	<ol style="list-style-type: none"> 1. Brake system (Fluid leaks) 2. Brake system (Air in) 3. Piston seals (Worn or damaged) 4. Master cylinder (Faulty) 5. Booster push rod (Out of adjustment) 	DI-269 DI-321 BR-4 BR-26 BR-35 BR-12 BR-22
Brake drag	<ol style="list-style-type: none"> 1. Brake pedal freeplay (Minimal) 2. Parking brake pedal travel (Out of adjustment) 3. Parking brake wire (Sticking) 4. Rear brake shoe clearance (Out of adjustment) 5. Pad (Cracked or distorted) 6. Piston (Stuck) 7. Piston (Frozen) 8. Tension or return spring (Faulty) 9. Booster push rod (Out of adjustment) 10. Vacuum leaks for booster system 11. Master cylinder (Faulty) 	BR-6 BR-8 – BR-44 BR-23 BR-32 BR-26 BR-35 BR-26 BR-35 BR-41 BR-22 BR-20 BR-12
Brake pull	<ol style="list-style-type: none"> 1. Piston (Stuck) 2. Pad (Oily) 3. Piston (Frozen) 4. Disc (Scored) 5. Pad (Cracked or distorted) 	BR-26 BR-35 BR-23 BR-32 BR-26 BR-35 BR-26 BR-35 BR-23 BR-32
Hard pedal but brake inefficient	<ol style="list-style-type: none"> 1. Brake system (Fluid leaks) 2. Brake system (Air in) 3. Piston (Stuck) 4. Pad (Cracked or distorted) 5. Pad (Oily) 6. Pad (Glazed) 7. Disc (Scored) 8. Booster push rod (Out of adjustment) 9. Vacuum leaks for booster system 	DI-269 DI-321 BR-4 BR-26 BR-35 BR-23 BR-32 BR-23 BR-32 BR-23 BR-32 BR-26 BR-35 BR-22 BR-20

BRAKE - TROUBLESHOOTING

Symptom	Suspect Area	See page
Noise from brake	<ol style="list-style-type: none"> 1. Pad (Cracked or distorted) 2. Installation bolt (Loosen) 3. Disc (Scored) 4. Pad support plate (Loosen) 5. Sliding pin (Worn) 6. Pad (Dirty) 7. Pad (Glazed) 8. Tension or return spring (Faulty) 9. Anti-squeal shim (Damage) 10. Hold-down spring (Damage) 	BR-23 BR-32 BR-26 BR-35 BR-26 BR-35 BR-23 BR-32 BR-26 BR-35 BR-23 BR-32 BR-23 BR-32 BR-41 BR-23 BR-32 BR-41

BRAKE FLUID BLEEDING

BR063-01

HINT:

If any work is done on the brake system or if air is suspected in the brake lines, bleed the system of air.

NOTICE:

Do not let brake fluid remain on a painted surface. Wash it off immediately.

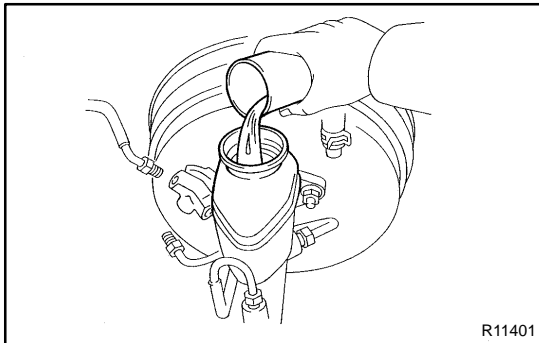

R11401

1. FILL BRAKE RESERVOIR WITH BRAKE FLUID

Check the fluid level in the reservoir after bleeding each wheel. Add fluid, if necessary.

Fluid: SAEJ1703 or FMVSS No.116 DOT 3

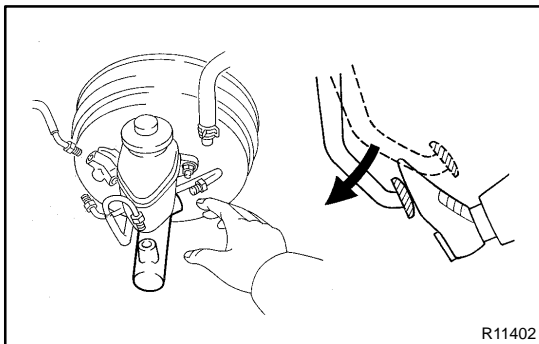

R11402

2. BLEED MASTER CYLINDER

HINT:

If the master cylinder has been disassembled or if the reservoir becomes empty, bleed the air from the master cylinder.

- (a) Disconnect the brake lines from the master cylinder.
- (b) Slowly depress the brake pedal and hold it.

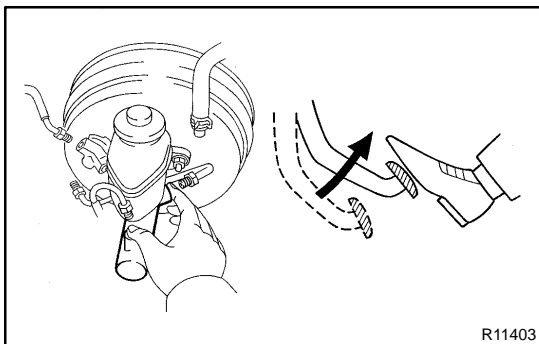

R11403

- (c) Block off the outlet plugs with your fingers, and release the brake pedal.
- (d) Repeat (b) and (c) 3 or 4 times.

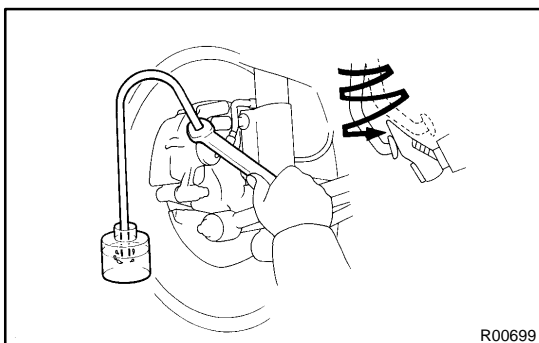

R00699

3. CONNECT VINYL TUBE TO BRAKE CALIPER BLEEDER PLUG

Insert the other end of the tube in a half-full container of brake fluid.

NOTICE:

Bleed air of the rear brake first. If front brake is bled first, rear brake air cannot be bled.

4. BLEED BRAKE LINE

- (a) Slowly depress the brake pedal several times.

- (b) While an assistant depresses the pedal, loosen the bleeder plug until fluid starts to run out. Then tighten the bleeder plug.
- (c) Repeat this procedure until there are no more air bubbles in the fluid.

Torque: (Bleeder plug)

8.3 N·m (85 kgf·cm, 74 in.-lbf)

5. REPEAT PROCEDURE FOR EACH WHEEL

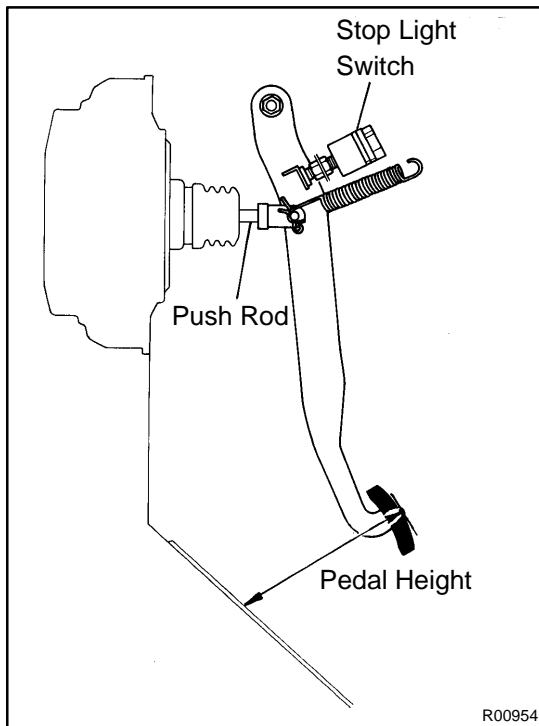

BRAKE PEDAL ON-VEHICLE INSPECTION

BR064-01

1. CHECK PEDAL HEIGHT

Pedal height from asphalt sheet:
152.0 – 162.0 mm (5.984 – 6.378 in.)

2. IF NECESSARY, ADJUST PEDAL HEIGHT

- Disconnect the connector from the stop light switch.
 - Loosen the stop light switch lock nut and remove the stop light switch.
 - Loosen the push rod lock nut.
 - Adjust the pedal height by turning the pedal push rod.
 - Tighten the push rod lock nut.
- Torque: 25 N·m (260 kgf·cm, 19 ft·lbf)**
- Install the stop light switch and turn it until it lightly contacts the pedal stopper.
 - Turn the stop light switch back one turn.

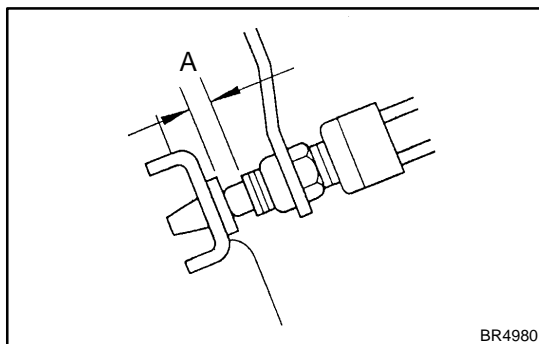

- Check the clearance (A) between the stop light switch and pedal.
- Clearance: 0.5 – 2.4 mm (0.020 – 0.094 in.)**
- Tighten the stop light switch lock nut.
 - Connect the connector to the stop light switch.
 - Check that the stop lights come on when the brake pedal is depressed, and go off when the brake pedal is released.
- After adjusting the pedal height, check the pedal freeplay.

HINT:

If clearance (A) between the stop light switch and the pedal stopper has been adjusted correctly, the pedal freeplay will meet the specifications.

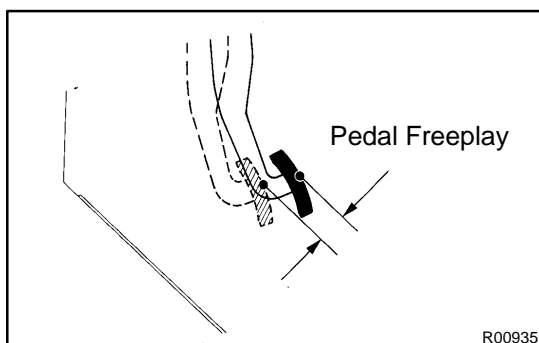

3. CHECK PEDAL FREEPLAY

- Stop the engine and depress the brake pedal several times until there is no more vacuum left in the booster.
- Push in the pedal by hand until the resistance begins to be felt, then measure the distance.

Pedal freeplay:
1 – 6 mm (0.04 – 0.24 in.)

HINT:

The freeplay to the 1st resistance is due to the play between the clevis and pin. This is magnified up to 1 – 6 mm (0.04 – 0.24 in.) at the pedal.

If incorrect, check the stop light switch clearance. If the clearance is OK, then troubleshoot the brake system.

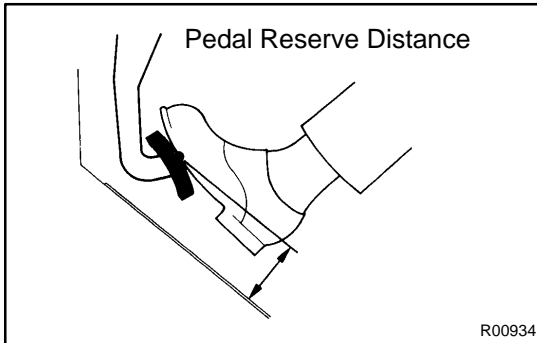
**4. CHECK PEDAL RESERVE DISTANCE**

- (a) Release the parking brake.
- (b) With the engine running, depress the pedal and measure the pedal reserve distance, as shown.

Pedal reserve distance from asphalt sheet at 490 N (50 kgf, 110.2 lbf): More than 70 mm (2.76 in.)

If the reserve distance is incorrect, troubleshoot the brake system.

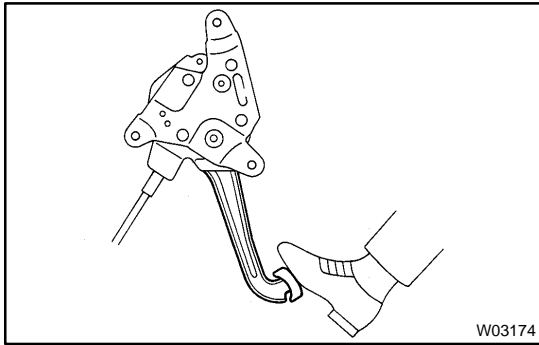

PARKING BRAKE PEDAL ON-VEHICLE INSPECTION

BR065-01

1. CHECK PARKING BRAKE PEDAL TRAVEL

Slowly depress the parking brake pedal all the way, and count the number of clicks.

**Parking brake pedal travel at 294 N (30 kgf, 66 lbf):
3 - 6 clicks**

If incorrect, adjust the parking brake.

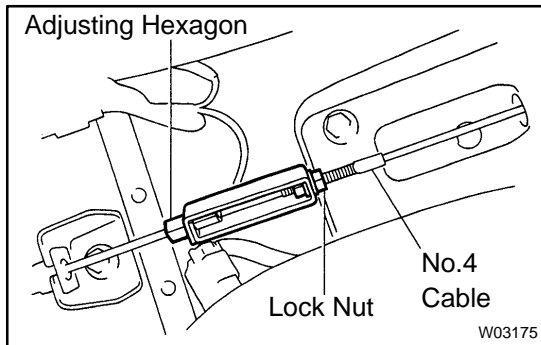

2. IF NECESSARY, ADJUST PARKING BRAKE PEDAL TRAVEL

HINT:

Before adjusting the parking brake, make sure that the rear brake shoe clearance has been adjusted.

For shoe clearance adjustment, see step 1 on page [BR-44](#).

- (a) Remove the console upper panel and console box.
- (b) Confirm that the parking pedal is released.
- (c) Hold the screw end of No.4 cable not to rotate.
- (d) Loosen the lock nut.
- (e) Hold the parking brake cable and turn the adjusting hexagon until the pedal travel is correct.

NOTICE:

To prevent the parking brake cable from twisting, must always keep the red-painted surface up.

- (f) Holding the adjusting hexagon, tighten the lock nut.
Torque: 5.4 N·m (55 kgf·cm, 48 in.-lbf)
- (g) Install the console box and console upper panel.

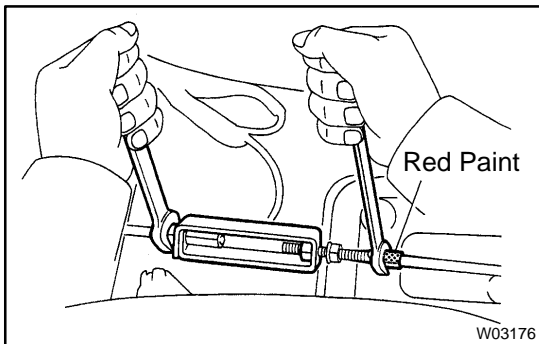

COMPONENTS

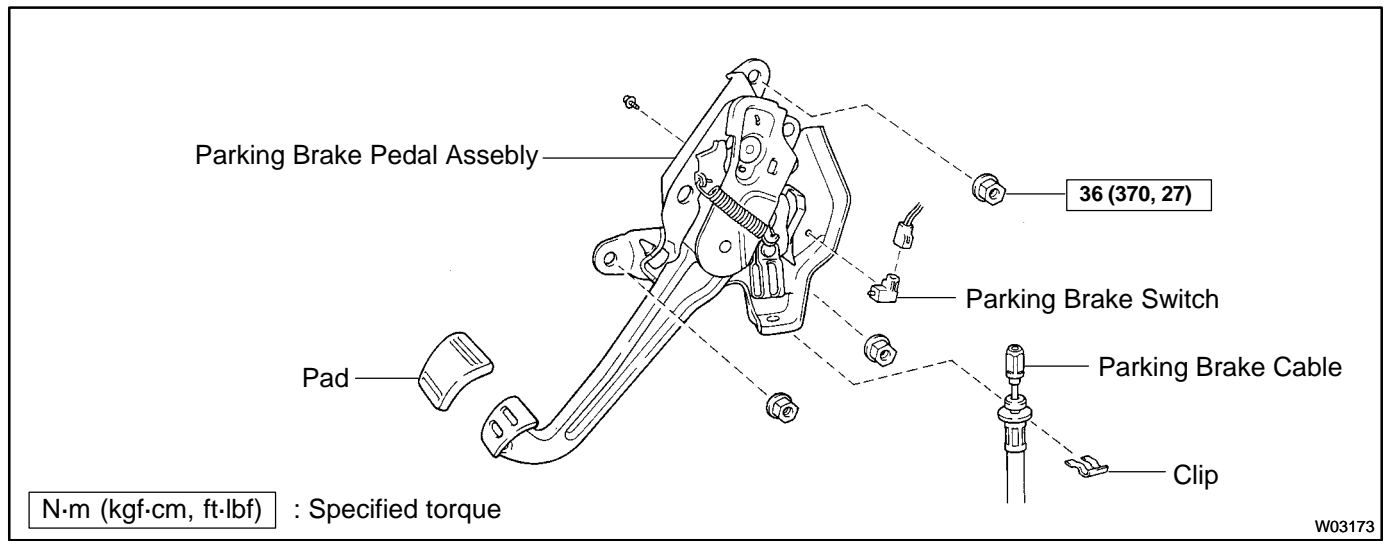

REMOVAL

1. **RELEASE PARKING BRAKE PEDAL**
2. **DISCONNECT PARKING BRAKE SWITCH CONNECTOR**
3. **REMOVE PARKING BRAKE PEDAL ASSEMBLY**

Remove the 3 nuts and parking brake pedal assembly.

Torque: 36 N·m (370 kgf·cm, 27 ft·lbf)

4. **DISCONNECT PARKING BRAKE WIRE**

Remove clip and disconnect the parking brake wire.

5. **REMOVE PARKING BRAKE SWITCH**

Remove the screw and parking brake switch.

INSTALLATION

Installation is in the reverse order of removal (See page [BR-10](#)).

BRAKE MASTER CYLINDER COMPONENTS

BR069-04

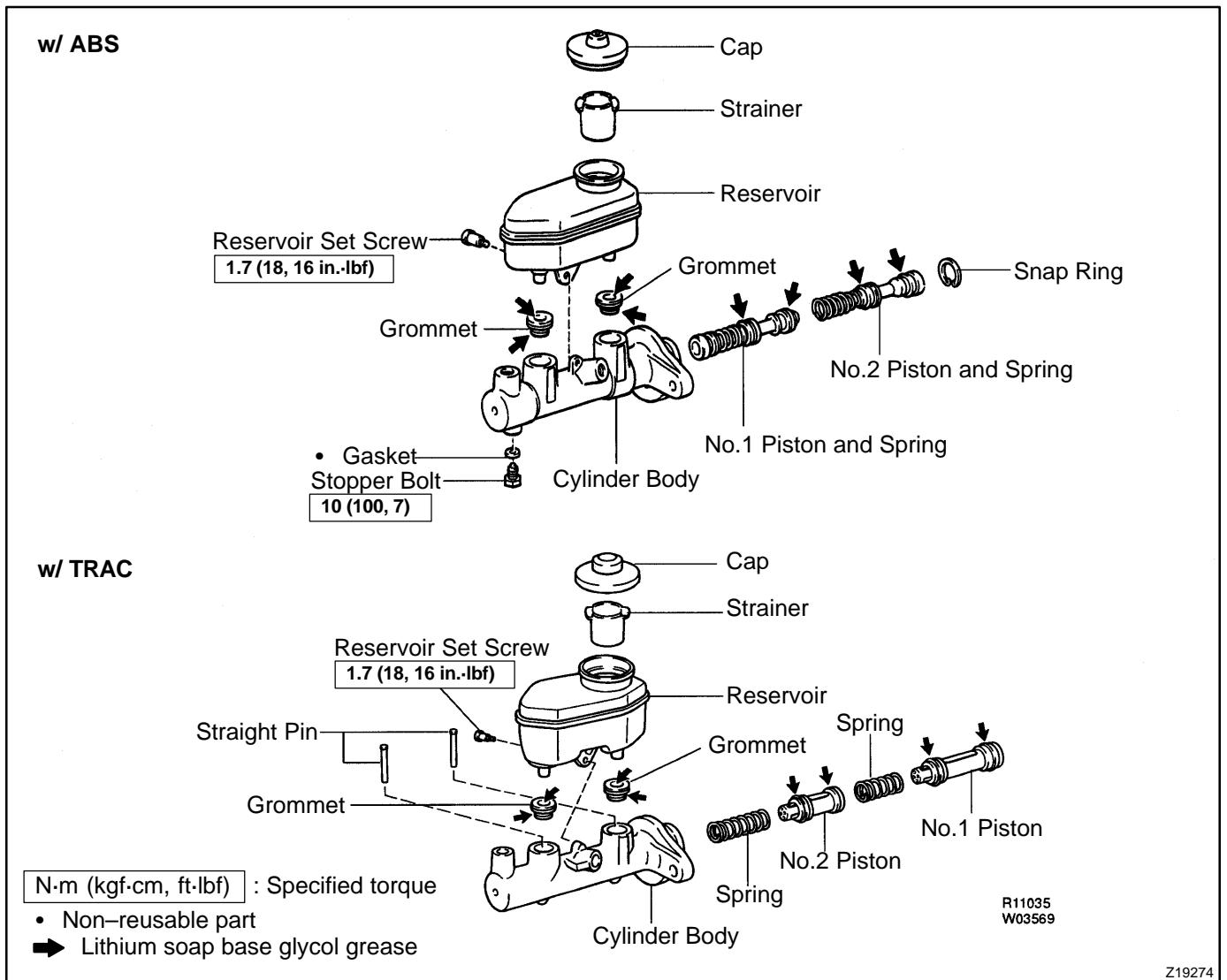
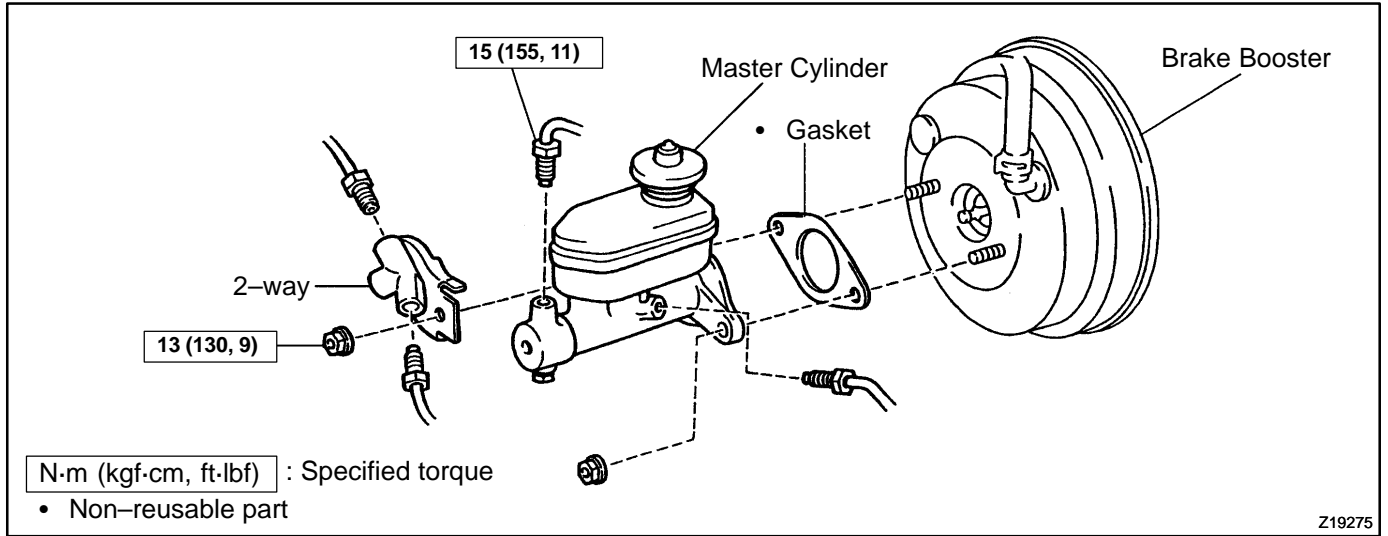

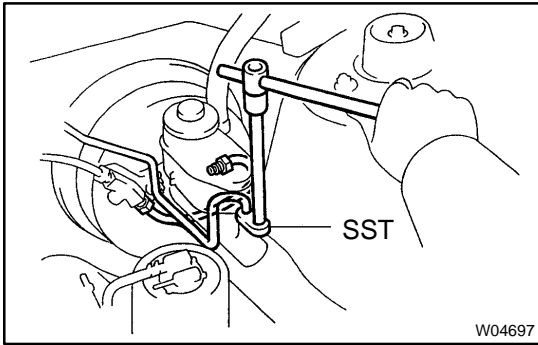

REMOVAL

1. DISCONNECT LEVEL WARNING SWITCH CONNECTOR
2. TAKE OUT FLUID WITH SYRINGE

NOTICE:

Do not let brake fluid remain on a painted surface. Wash it off immediately.

3. DISCONNECT BRAKE LINES

Using SST, disconnect the 5 brake lines.

SST 09023-00100

Torque: 15 N·m (155 kgf·cm, 11 ft·lbf)

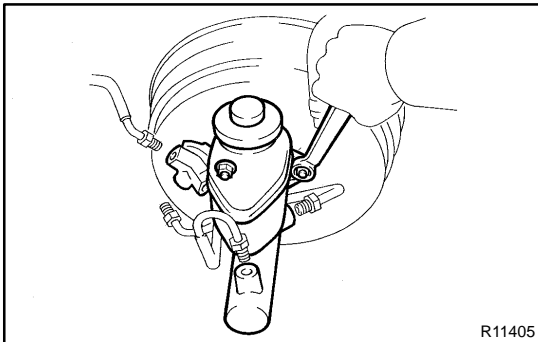

4. REMOVE MASTER CYLINDER

Remove the 2 nuts, and pull out the 2-way, master cylinder and gasket.

Torque: 13 N·m (130 kgf·cm, 9 ft·lbf)

DISASSEMBLY

1. REMOVE RESERVOIR

- (a) Remove the set screw and pull out the reservoir.

Torque: 1.7 N·m (18 kgf·cm, 16 in.-lbf)

- (b) Remove the cap and strainer from the reservoir.

2. REMOVE 2 GROMMETS

3. w/ ABS:

PLACE CYLINDER IN VISE

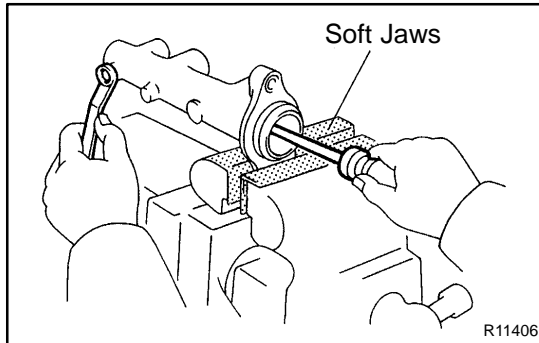

4. REMOVE PISTON STOPPER BOLT

Using a screwdriver, push the pistons in all the way and remove the piston stopper bolt and gasket.

HINT:

Tape the screwdriver tip before use.

Torque: 10 N·m (100 kgf·cm, 7 ft-lbf)

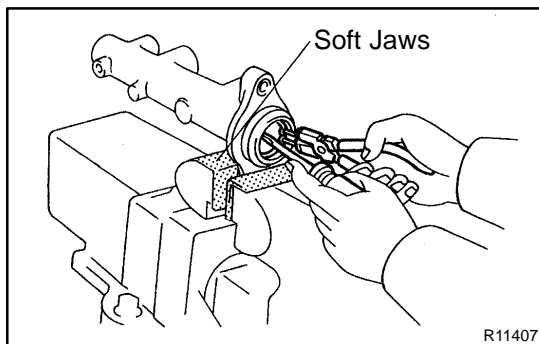

5. REMOVE 2 PISTONS AND SPRINGS

- (a) Push in the piston with a screwdriver and remove the snap ring with snap ring pliers.

HINT:

Tape the screwdriver tip before use.

- (b) Remove the No.1 piston and spring by hand, pulling straight out, not at an angle.

NOTICE:

- If pulled out and installed at an angle, there is a possibility that the cylinder bore could be damaged.
- At the time reassembly, be careful not to damage the rubber lips on the pistons.

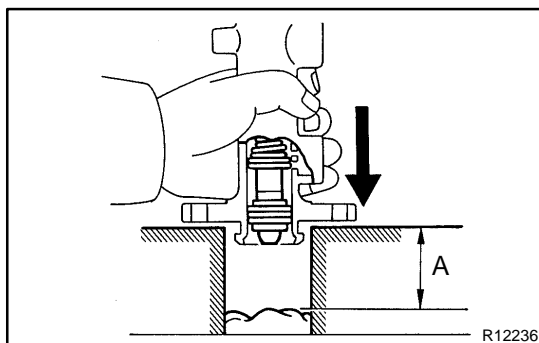

- (c) Place a rag and 2 wooden blocks on the work table, and lightly tap the cylinder flange against the block edges until the No.2 piston drops out of the cylinder.

HINT:

Make sure that the distance (A) from the rag to the top of the blocks is at least 100 mm (3.94 in.).

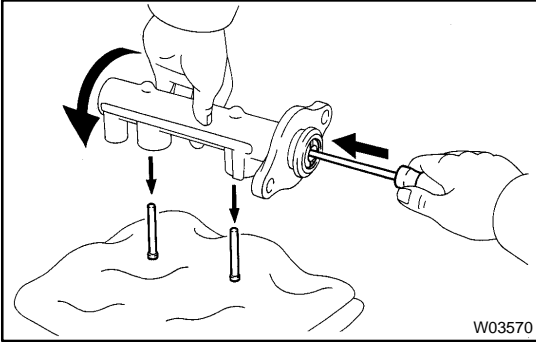
**6. w/ TRAC:****REMOVE 2 PISTONS AND SPRINGS**

- (a) Push in the piston with a screwdriver, and remove the 2 straight pins by turning over the cylinder body.

HINT:

Tape the screwdriver tip before use.

- (b) Remove the 2 pistons and springs by hand, pulling straight out, not at angle.

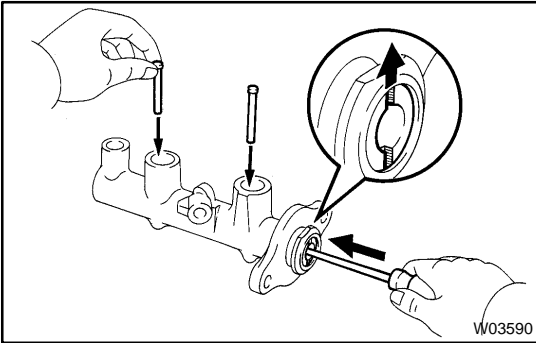
**NOTICE:**

- **If pulled out and installed at an angle, there is a possibility that the cylinder bore could be damaged.**
- **At the time of reassembly, be careful not to damage the rubber lips on the pistons.**

HINT:

At the time of reassembly, insert the pistons with elliptic hole facing vertically.

INSPECTION

HINT:

Clean the disassembled parts with compressed air.

1. **INSPECT CYLINDER BORE FOR RUST OR SCORING**
2. **INSPECT CYLINDER FOR WEAR OR DAMAGE**

If necessary, clean or replace the cylinder.

REASSEMBLY

Reassembly is in the reverse order of disassembly (See page [BR-14](#)).

NOTICE:

Apply lithium soap base glycol grease to the rubber parts indicated by the arrows (See page [BR-12](#)).

INSTALLATION

Installation is in the reverse order of removal (See page [BR-13](#)).

1. BEFORE INSTALLATION, ADJUST LENGTH OF BRAKE BOOSTER PUSH ROD (See page [BR-22](#))
2. AFTER INSTALLATION, FILL BRAKE RESERVOIR WITH BRAKE FLUID AND BLEED BRAKE SYSTEM (See page [BR-4](#))
3. CHECK FOR LEAKS, CHECK AND ADJUST BRAKE PEDAL (See page [BR-6](#))

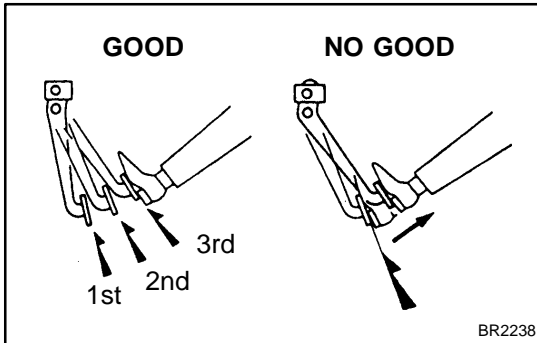
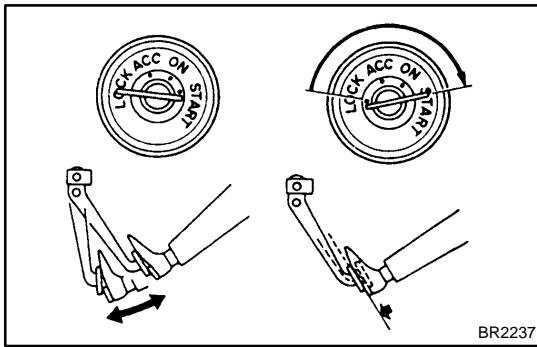

BRAKE BOOSTER ASSEMBLY ON-VEHICLE INSPECTION

BR06F-01

1. OPERATING CHECK

- (a) Depress the brake pedal several times with the engine off and check that there is no change in the pedal reserve distance.
- (b) Depress the brake pedal and start the engine. If the pedal goes down slightly, operation is normal.

2. AIR TIGHTNESS CHECK

- (a) Start the engine and stop it after 1 or 2 minutes. Depress the brake pedal several times slowly.

If the pedal goes down farthest the 1st time, but gradually rises after the 2nd or 3rd time, the booster is air tight.

- (b) Depress the brake pedal while the engine is running, and stop the engine with the pedal depressed. If there is no change in the pedal reserve travel after holding the pedal for 30 seconds, the booster is air tight.

COMPONENTS

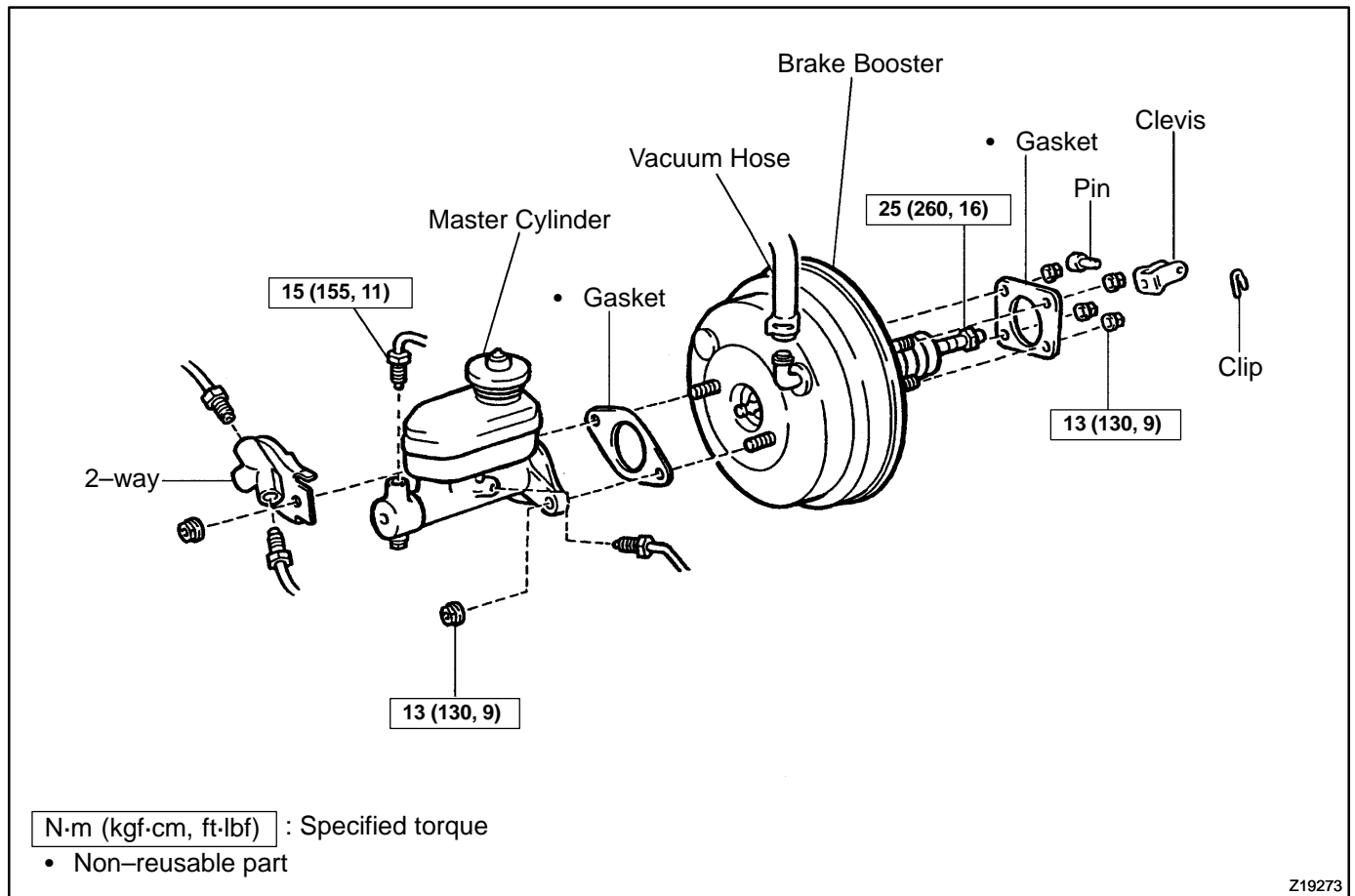

Z19273

REMOVAL

1. REMOVE AIR CLEANER COVER WITH AIR CLEANER HOSE
2. REMOVE MASTER CYLINDER (See page BR-13)
3. REMOVE CHARCOAL CANISTER
4. DISCONNECT VACUUM HOSE FROM BRAKE BOOSTER
5. REMOVE PEDAL RETURN SPRING
6. REMOVE CLIP AND CLEVIS PIN
7. REMOVE BRAKE BOOSTER, GASKET AND CLEVIS
 - (a) Remove the 4 nuts and clevis.
 - (b) Pull out the brake booster and gasket.

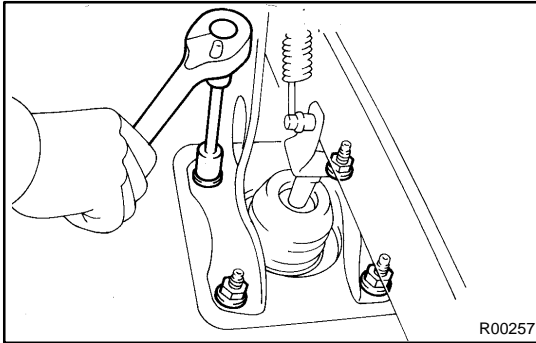

INSTALLATION

1. INSTALL BRAKE BOOSTER

- (a) Install the booster and a new gasket.
- (b) Install the clevis to the operating rod.
- (c) Install and torque the booster installation nuts.
Torque: 13 N·m (130 kgf-cm, 9 ft-lbf)
- (d) Install the clevis, and torque the lock nut.
Torque: 25 N·m (260 kgf-cm, 19 ft-lbf)
- (e) Install the clevis pin into the clevis and brake pedal, and install the clip to the clevis pin.
- (f) Install the pedal return spring.

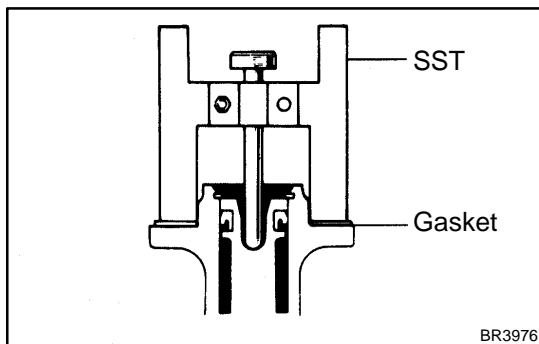

2. ADJUST LENGTH OF BOOSTER PUSH ROD

- (a) Install a new gasket on the master cylinder.
- (b) Set the SST on the gasket, and lower the pin until its tip slightly touches the piston.
SST 09737-00010

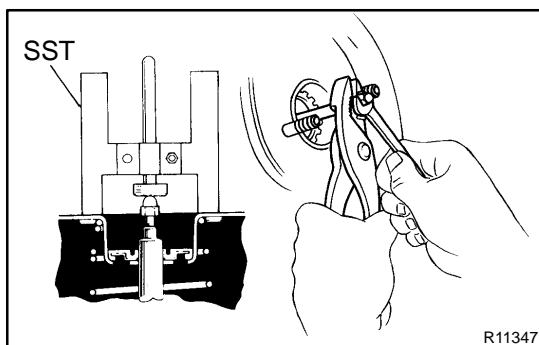

- (c) Turn the SST upside down, and set it on the booster.
SST 09737-00010
- (d) Measure the clearance between the booster push rod and pin head (SST).
Clearance: 0 mm (0 in.)
- (e) Adjust the booster push rod length until the push rod lightly touches the pin head.

3. INSTALL CHARCOAL CANISTER TO ORIGINAL POSITION

4. INSTALL MASTER CYLINDER (See page [BR-18](#))
5. INSTALL AIR CLEANER COVER WITH AIR CLEANER HOSE
6. CONNECT VACUUM HOSE TO BRAKE BOOSTER
7. FILL BRAKE RESERVOIR WITH BRAKE FLUID AND BLEED BRAKE SYSTEM (See page [BR-4](#))
8. CHECK FOR FLUID LEAKAGE
9. CHECK AND ADJUST BRAKE PEDAL (See page [BR-6](#))
10. DO OPERATIONAL CHECK (See page [BR-19](#))

FRONT BRAKE PAD COMPONENTS

BR06J-03

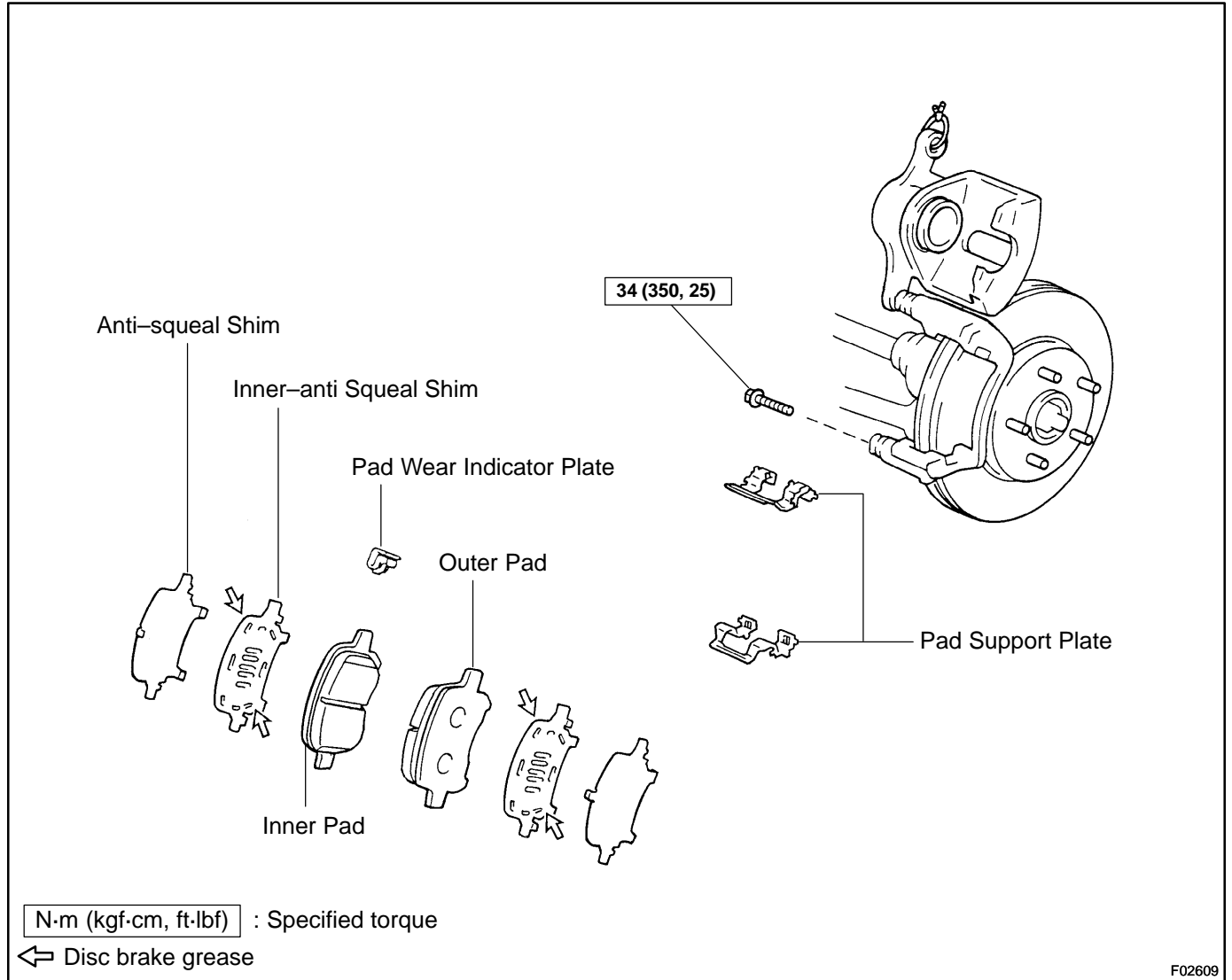

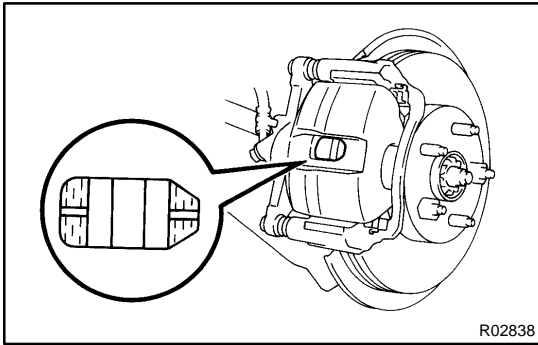

REPLACEMENT

1. REMOVE FRONT WHEEL

Remove the wheel and temporarily fasten the disc with hub nuts.

2. INSPECT PAD LINING THICKNESS

Check the pad thickness through the caliper inspection hole and replace the pads if they are not within the specification.

Minimum thickness: 1.0 mm (0.039 in.)

3. LIFT UP CALIPER

- Remove the bolt and flexible hose from the shock absorber.
- Remove the bottom side installation bolt.
- Lift up the caliper and suspend it securely.

HINT:

Do not disconnect the flexible hose from the caliper.

4. REMOVE THESE PARTS:

- 2 brake pads
- 4 anti-squeal shims
- Pad wear indicator plate
- 2 pad support plates

NOTICE:

The support plates can be used again provided that they have sufficient rebound, no deformation, cracks or wear, and have had all rust, dirt and foreign particles cleaned off.

5. CHECK DISC THICKNESS AND RUNOUT

(See page [BR-29](#))

6. INSTALL 2 PAD SUPPORT PLATES

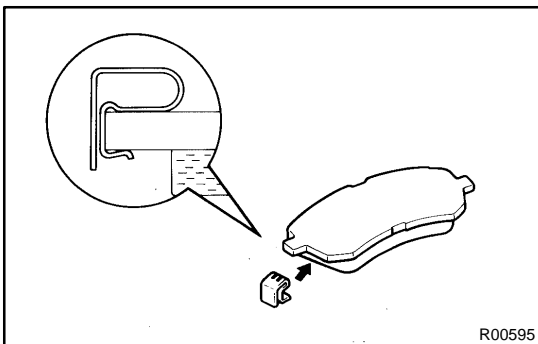

7. INSTALL NEW PADS

NOTICE:

When replacing worn pads, the anti-squeal shims and wear indicator plates must be replaced together with the pads.

- Install a pad wear indicator plate on the inner pad.
- Apply disc brake grease to both sides of the inner anti-squeal shim (See page [BR-23](#)).
- Install the 2 anti-squeal shims on each pad.
- Install inner pad with the pad wear indicator plate facing upward.
- Install outer pad.

NOTICE:

There should be no oil or grease adhering to the friction surfaces of the pads or the disc.

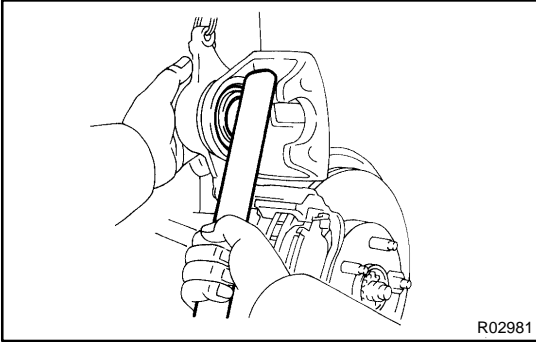
**8. INSTALL CALIPER**

- (a) Draw out a small amount of brake fluid from the reservoir.
- (b) Press in the piston with a hammer handle or similar implement.

HINT:

If the piston is difficult to push in, loosen the bleeder plug and push in the piston while letting some brake fluid escape.

- (c) Install the caliper.
- (d) Install the installation bolt.

Torque: 34 N·m (350 kgf-cm, 25 ft-lbf)

- (e) Install the flexible hose and bolt to the shock absorber.

Torque: 29 N·m (300 kgf-cm, 21 ft-lbf)

9. INSTALL FRONT WHEEL**10. CHECK THAT FLUID LEVEL IS AT MAX LINE**

FRONT BRAKE CALIPER COMPONENTS

BR06L-03

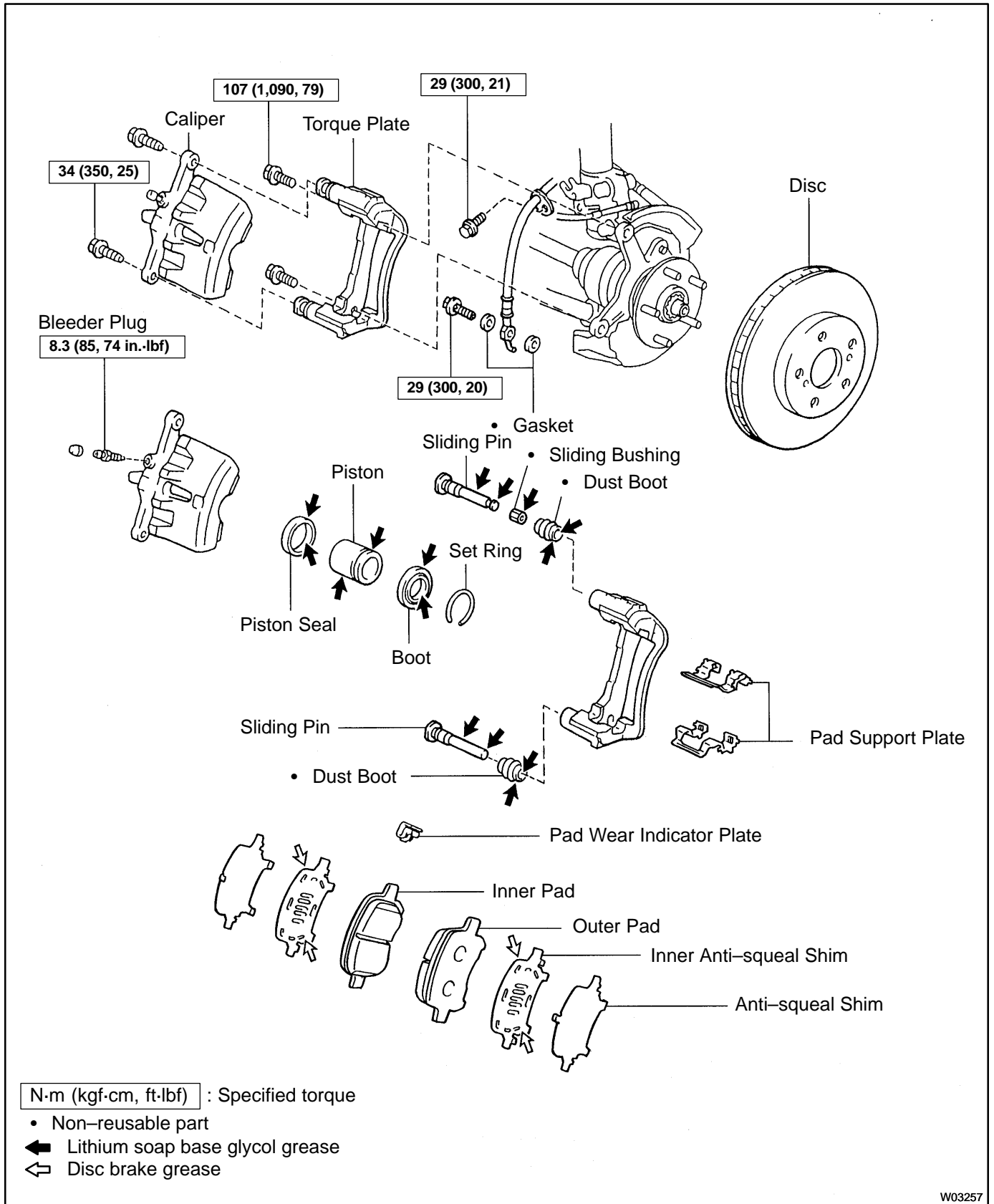

W03257

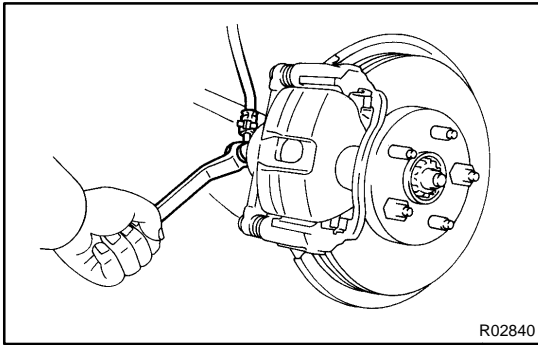

REMOVAL

1. **REMOVE FRONT WHEEL**
2. **DISCONNECT FLEXIBLE HOSE**
 - (a) Remove the union bolt and 2 gaskets from the caliper, then disconnect the flexible hose from the caliper.
Torque: 29 N·m (300 kgf·cm, 21 ft·lbf)

HINT:

At the time of installation, please refer to the following item. Install the flexible hose lock securely in the lock hole in the caliper.

- (b) Use a container to catch the brake fluid as it drains out.
3. **REMOVE CALIPER**
 - (a) Remove the 2 installation bolts.
Torque: 34 N·m (350 kgf·cm, 25 ft·lbf)
 - (b) Remove the caliper from the torque plate.
4. **REMOVE THESE PARTS:**
 - (a) 2 brake pads with anti-squeal shims
 - (b) 2 pad support plates

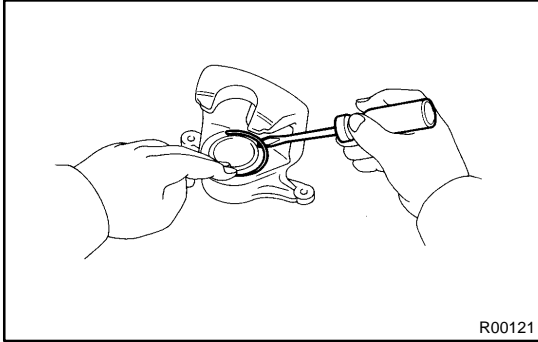

R00121

DISASSEMBLY

1. REMOVE SET RING AND CYLINDER BOOT

Using a screwdriver, remove the set ring and cylinder boot from the caliper.

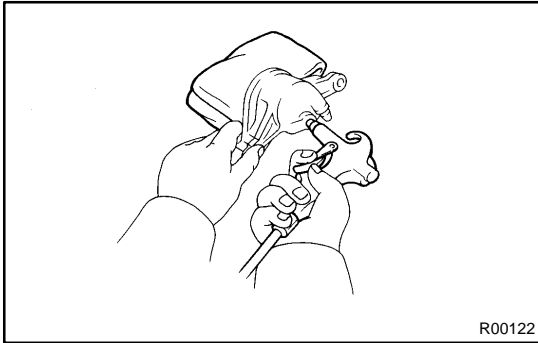

R00122

2. REMOVE PISTON

- (a) Place a piece of cloth or similar, between the piston and the caliper.
- (b) Use compressed air to remove the piston from the cylinder.

CAUTION:

Do not place your fingers in front of the piston when using compressed air.

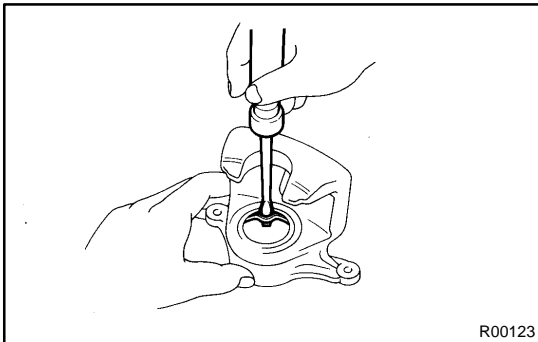

R00123

3. REMOVE PISTON SEAL

Using a screwdriver, remove the piston seal from the cylinder.

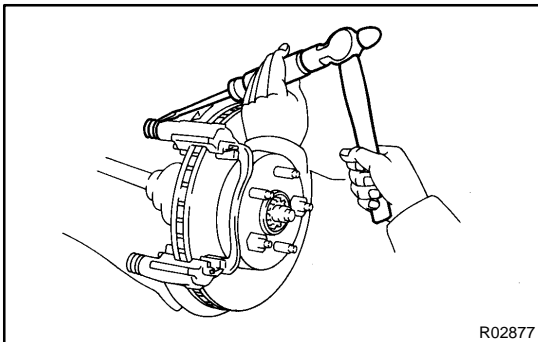

R02877

4. REMOVE SLIDING PINS AND DUST BOOTS

- (a) Remove the 2 sliding pins from the torque plate.

NOTICE:

At the time of reassembly, please refer to the following item. Insert the sliding pin with sliding bushing into the top side.

- (b) Using a screwdriver and hammer, tap out the 2 dust boots.

HINT:

At the time of reassembly, please refer to the following item. Use a 24 mm socket wrench and tap in 2 new dust boots into the torque plate.

NOTICE:

At the time of reassembly, please refer to the following item. Check that the metal plate portion of the dust boot fits snugly in the torque plate.

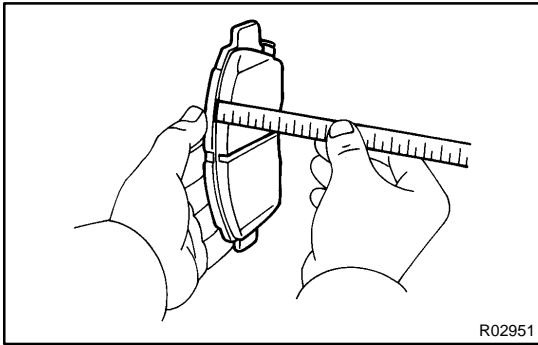

INSPECTION

1. MEASURE PAD LINING THICKNESS

Using a ruler, measure the pad lining thickness.

Standard thickness: 11.0 mm (0.433 in.)

Minimum thickness: 1.0 mm (0.039 in.)

Replace the pad if the pad's thickness is at the minimum thickness or less, or if the pad has severe and uneven wear.

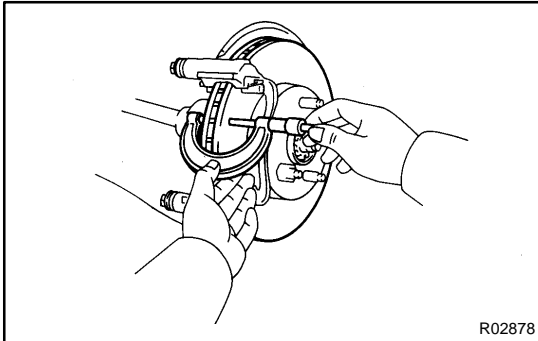

2. MEASURE DISC THICKNESS

Using a micrometer, measure the disc thickness.

Standard thickness: 28.0 mm (1.102 in.)

Minimum thickness: 26.0 mm (1.024 in.)

Replace the disc if the disc's thickness is at the minimum thickness or less. Replace the disc or grind it on a lathe if it is badly scored or worn unevenly.

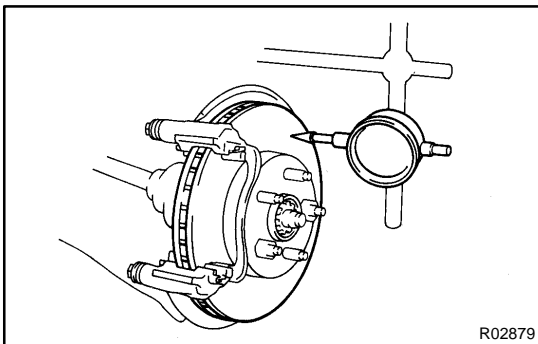

3. MEASURE DISC RUNOUT

Using a dial indicator, measure disc runout 10 mm (0.39 in.) away from the outer edge of the disc.

Maximum disc runout: 0.05 mm (0.0020 in.)

If the disc's runout is the maximum value or greater, check the bearing play in the axial direction and check the axle hub runout (See page SA-9). If the bearing play and axle hub runout are not abnormal, adjust the disc runout or grind it on a "On-Car" brake lathe.

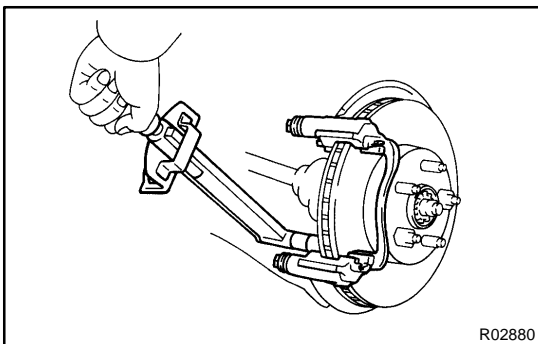

4. IF NECESSARY, ADJUST DISC RUNOUT

- (a) Remove the torque plate from the knuckle.
- (b) Remove the hub nuts and the disc. Reinstall the disc in the position turned 1/5 from its original position on the hub. Install and torque the hub nuts.

Torque: 103 N·m (1,050 kgf·cm, 76 ft·lbf)

Remeasure the disc runout. Make a note of the runout and the disc's position on the hub.

- (c) Repeat (b) until the disc has been installed on the 3 remaining hub positions.
- (d) If the minimum runout recorded in (b) and (c) is less than 0.05 mm (0.0020 in.), install the disc in that position.
- (e) If the minimum runout recorded in (b) and (c) is greater than 0.05 mm (0.0020 in.), replace the disc and repeat step 3.
- (f) Install the torque plate and torque the mounting bolts.
Torque: 107 N·m (1,090 kgf·cm, 79 ft·lbf)

REASSEMBLY

Reassembly is in the reverse order of disassembly (See page [BR-28](#)).

NOTICE:

Apply lithium soap base glycol grease to the parts indicated by arrows (See page [BR-26](#)).

INSTALLATION

Installation is in the reverse order of removal (See page [BR-27](#)).

1. AFTER INSTALLATION, FILL BRAKE RESERVOIR WITH BRAKE FLUID AND BLEED BRAKE SYSTEM (See page [BR-4](#))
2. CHECK FOR LEAKS

REAR BRAKE PAD COMPONENTS

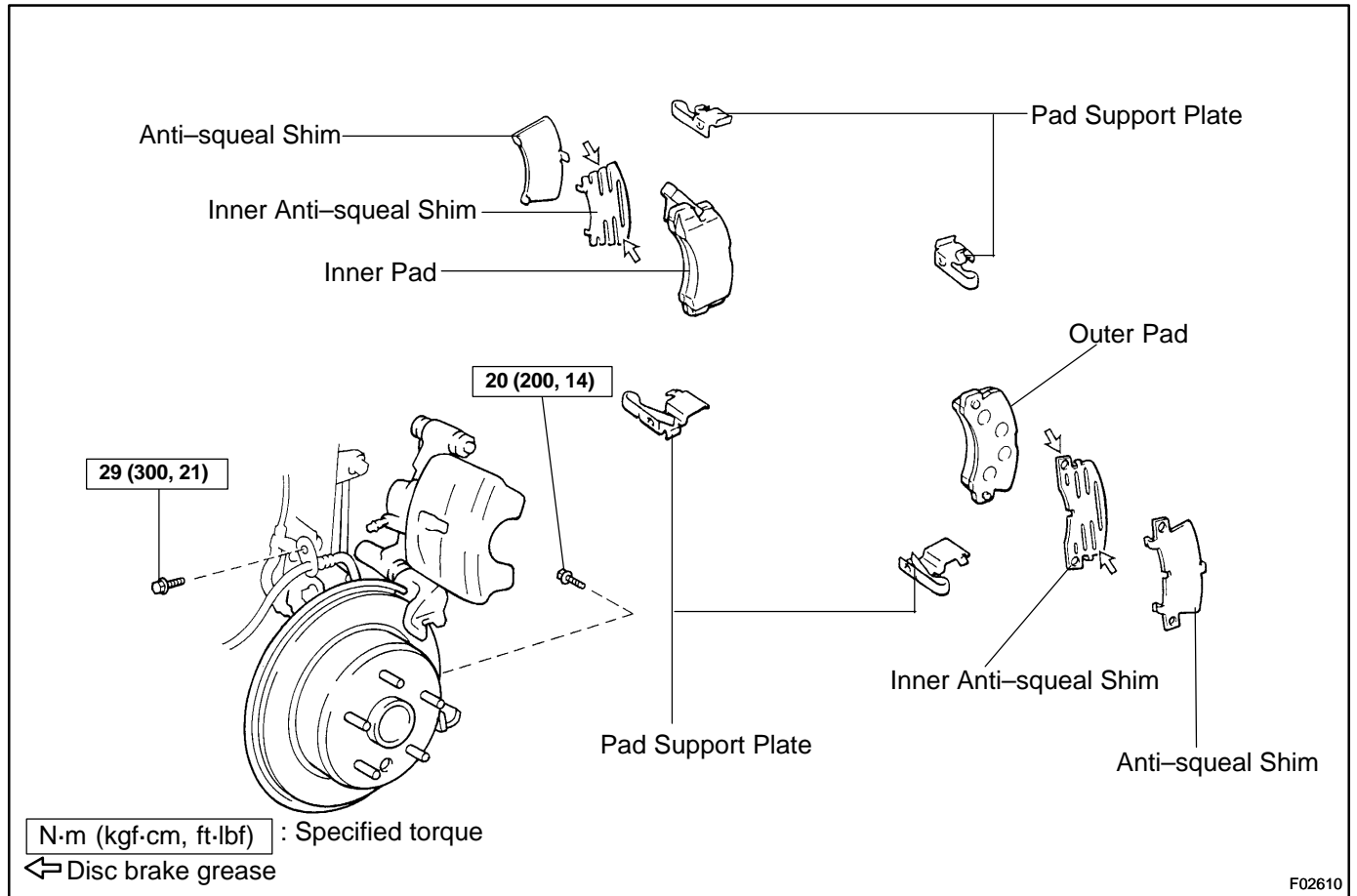

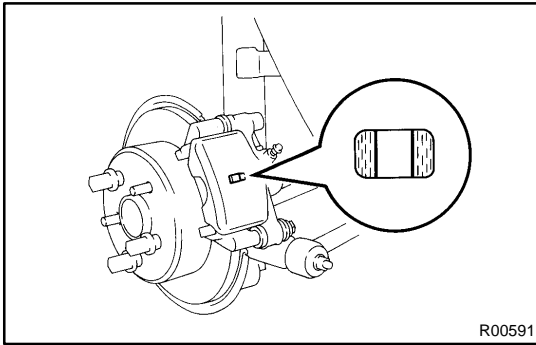

REPLACEMENT

1. REMOVE REAR WHEEL

Remove the wheel and temporarily fasten the disc with the hub nuts.

2. INSPECT PAD LINING THICKNESS

Check the pad thickness through the caliper inspection hole and replace pads if not within specification.

Minimum thickness: 1.0 mm (0.039 in.)

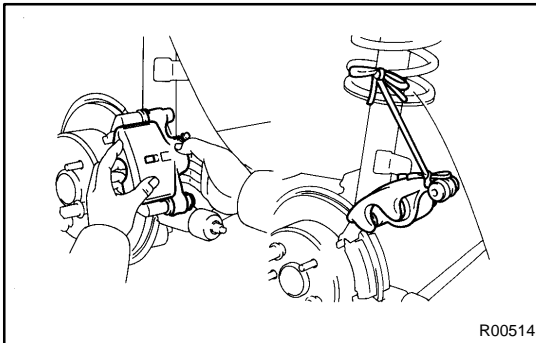

3. LIFT UP CALIPER

(a) Remove the bolt and flexible hose from the shock absorber.

(b) Remove the installation bolt from the torque plate.

(c) Lift up the caliper and suspend it securely.

HINT:

Do not disconnect the flexible hose.

4. REMOVE THESE PARTS:

(a) 2 brake pads

(b) 4 anti-squeal shims

(c) 4 pad support plates

NOTICE:

The support plates can be used again provided that they have sufficient rebound, no deformation, cracks or wear, and have had all rust, dirt and foreign particles cleaned off.

5. CHECK DISC THICKNESS AND RUNOUT

(See page [BR-29](#))

6. INSTALL 4 PAD SUPPORT PLATES

7. INSTALL NEW PADS

NOTICE:

When replacing worn pads, the anti-squeal shims must be replaced together with the pads.

(a) Apply disc brake grease to both side of the inner anti-squeal shims (See page [BR-32](#)).

(b) Install the 2 anti-squeal shims on each pad.

(c) Install 2 pads with the pad wear indicator plate facing upward.

NOTICE:

There should be no oil or grease adhering to the friction surfaces of the pads or the disc.

8. INSTALL CALIPER

(a) Draw out a small amount of brake fluid from the reservoir.

(b) Press in the piston with a hammer handle or similar implement.

HINT:

If the piston is difficult to push in, loosen the bleeder plug and push in the piston while letting some brake fluid escape.

(c) Install the caliper and torque the installation bolt.

Torque: 20 N·m (200 kgf·cm, 14 ft·lbf)

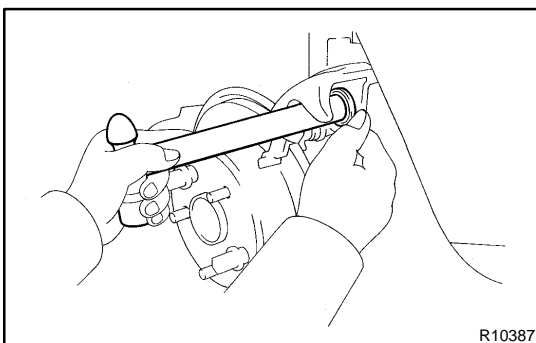

- (d) Install the flexible hose and bolt to the shock absorber.
Torque: 29 N·m (300 kgf-cm, 21 ft-lbf)
- 9. INSTALL REAR WHEEL**
- 10. CHECK THAT FLUID LEVEL IS AT MAX LINE**

REAR BRAKE CALIPER COMPONENTS

BR06T-04

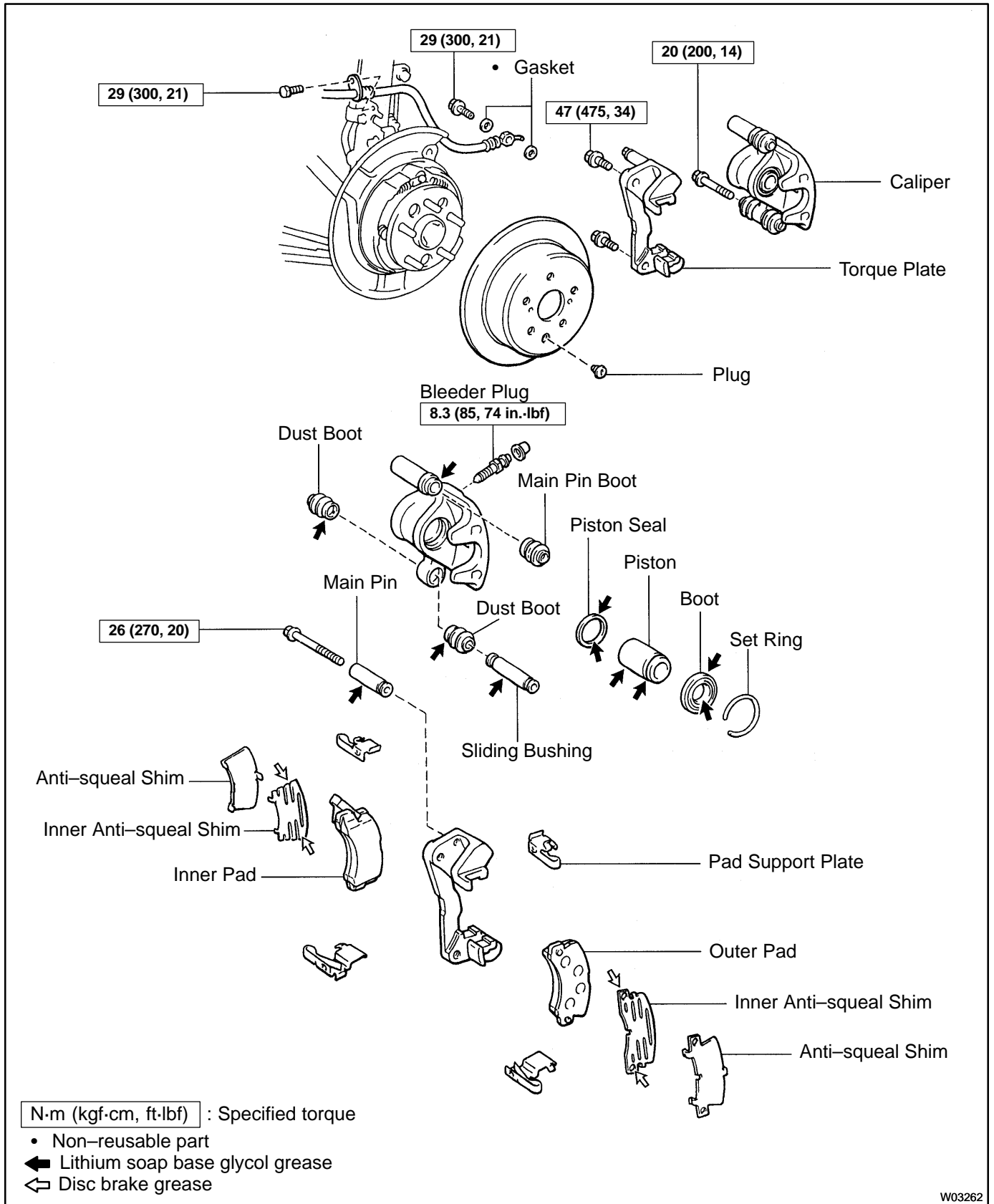

W03262

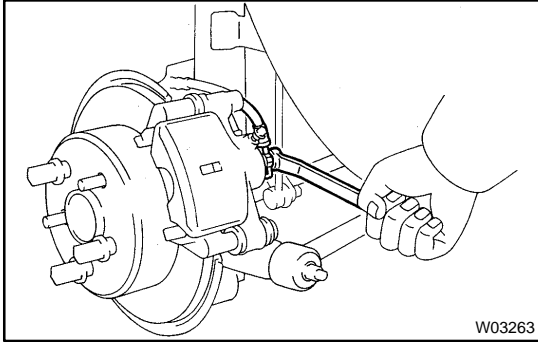

REMOVAL

1. REMOVE REAR WHEEL

2. DISCONNECT FLEXIBLE HOSE

- (a) Remove the union bolt and 2 gaskets from the caliper, then disconnect the flexible hose from the caliper.

Torque: 29 N·m (300 kgf-cm, 21 ft-lbf)

HINT:

At the time of installation, please refer to the following item. Insert the flexible hose lock securely in the lock hole in the caliper.

- (b) Use a container to catch the brake fluid as it drains out.

3. REMOVE CALIPER

- (a) Remove the installation bolt.

Torque: 20 N·m (200 kgf-cm, 14 ft-lbf)

- (b) Remove the caliper from the torque plate.

4. REMOVE THESE PARTS:

- (a) 2 brake pads with anti-squeal shims
 (b) 4 pad support plates

NOTICE:

At the time of installation, please refer to the following item. There should be no oil or grease adhering to the friction surfaces of the pads or disc.

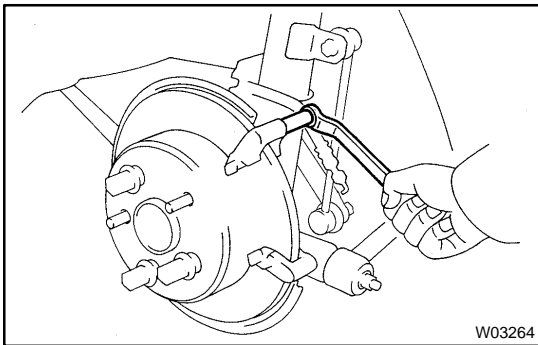

5. REMOVE MAIN PIN

Loosen the main pin installation bolt and remove the main pin.

Torque: 26 N·m (270 kgf-cm, 20 ft-lbf)

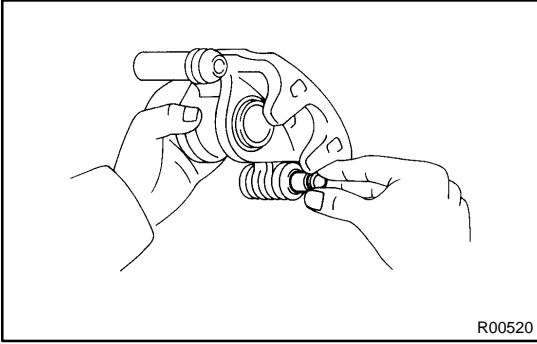

DISASSEMBLY

1. REMOVE THESE PARTS:

- (a) Sliding bushing
- (b) 2 dust boots
- (c) Main pin boot

NOTICE:

Ensure that the boots are secured firmly to the bushing and caliper grooves.

- 2. REMOVE CYLINDER BOOT SET RING AND BOOT (See step 1 on page [BR-28](#))
- 3. REMOVE PISTON (See step 2 on page [BR-28](#))
- 4. REMOVE PISTON SEAL (See step 3 on page [BR-28](#))

INSPECTION

1. **MEASURE PAD LINING THICKNESS**
(See step 1 on page BR-29)
Standard thickness: 10.0 mm (0.394 in.)
Minimum thickness: 1.0 mm (0.039 in.)
2. **MEASURE DISC THICKNESS**
(See step 2 on page BR-29)
Standard thickness: 10.0 mm (0.394 in.)
Minimum thickness: 9.0 mm (0.354 in.)
3. **MEASURE DISC RUNOUT**
(See step 3 on page BR-29)
Maximum disc runout: 0.15 mm (0.0059 in.)

If the disc's runout is maximum value or greater, check the bearing play in the axial direction and check the axle hub runout (See page SA-46). If the bearing play and axle hub runout are not abnormal, adjust the disc runout or grind it on a "On-Car" brake lathe.

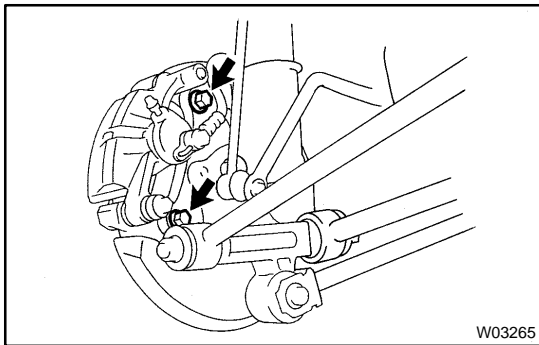

4. **IF NECESSARY, ADJUST DISC RUNOUT**
 - (a) Remove the 2 bolts and torque plate.
 - (b) Remove the hub nuts and the disc. Reinstall the disc in the position turned 1/5 from its original position on the hub. Install and torque the hub nuts.
Torque: 103 N·m (1,050 kgf·cm, 76 ft·lbf)
Remeasure the disc runout. Make a note of the runout and the disc's position on the hub.
 - (c) Repeat (b) until the disc has been installed on the 3 remaining hub positions.
 - (d) If the minimum runout recorded in (b) and (c) is less than 0.15 mm (0.0059 in.), install the disc in that position.
 - (e) If the minimum runout recorded in (b) and (c) is greater than 0.15 mm (0.0059 in.), replace the disc and repeat step 3.
 - (f) Install the torque plate and torque the mounting bolts.
Torque: 47 N·m (475 kgf·cm, 34 ft·lbf)

REASSEMBLY

Reassembly is in the reverse order of disassembly (See page [BR-37](#)).

NOTICE:

Apply lithium soap base glycol grease to the parts indicated by the arrows (See page [BR-35](#)).

INSTALLATION

Installation is in the reverse order of removal (See page [BR-36](#)).

1. AFTER INSTALLATION, FILL BRAKE RESERVOIR WITH BRAKE FLUID AND BLEED BRAKE SYSTEM (See page [BR-4](#))
2. CHECK FOR LEAKS

PARKING BRAKE COMPONENTS

BR06Z-04

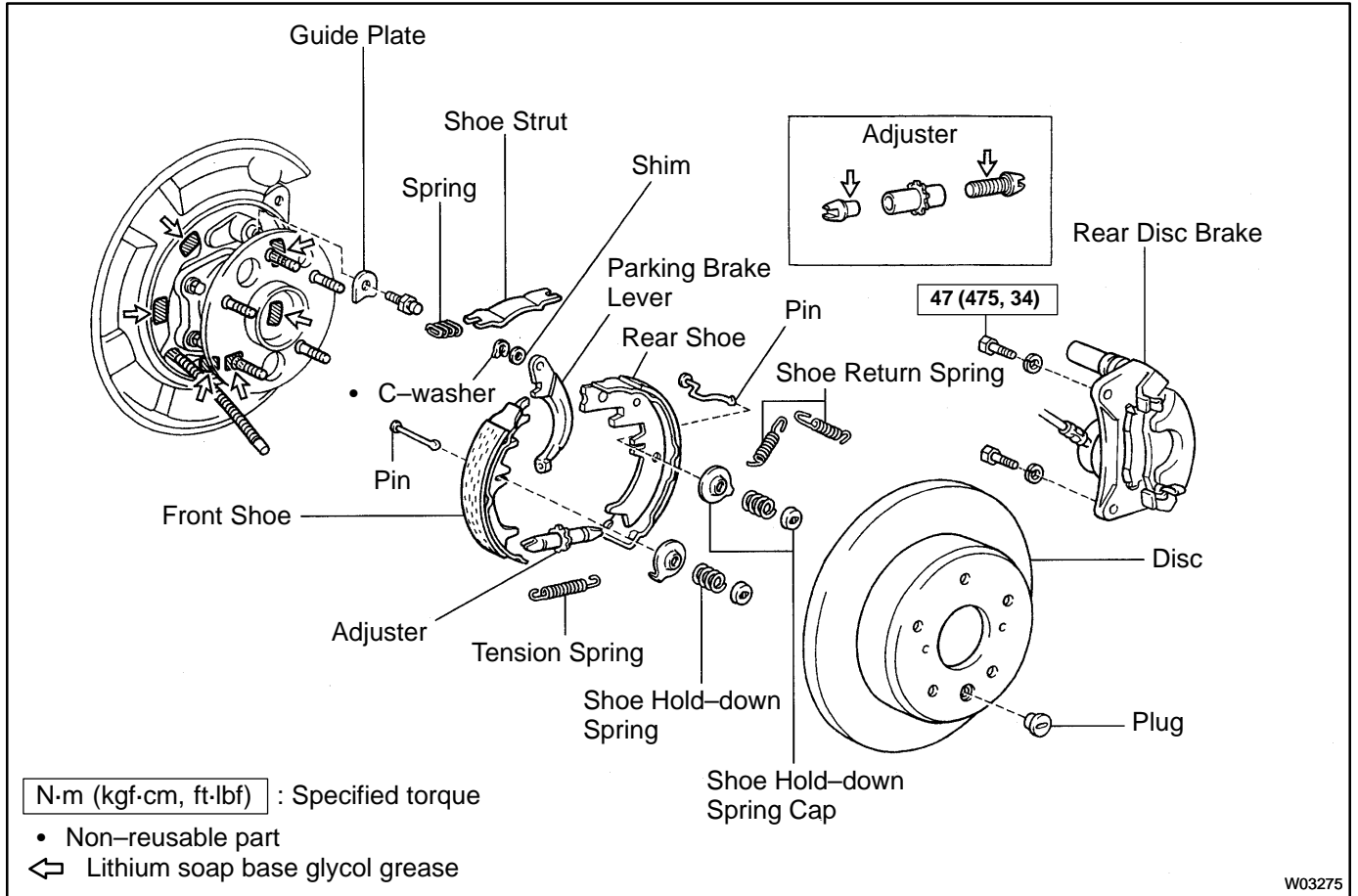

W03275

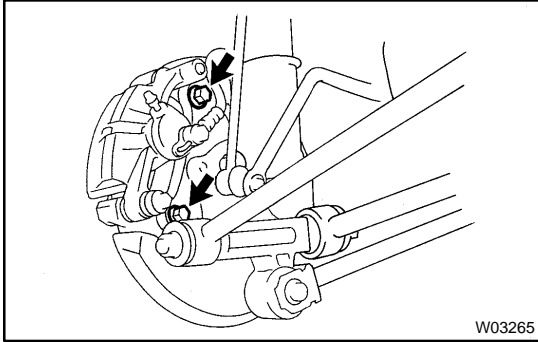

DISASSEMBLY

1. REMOVE REAR WHEEL

2. REMOVE REAR DISC BRAKE ASSEMBLY

- (a) Remove the 2 mounting bolts and remove the disc brake assembly.

Torque: 47 N·m (475 kgf·cm, 34 ft·lbf)

- (b) Suspend the disc brake securely. Ensure that the hose is not stretched.

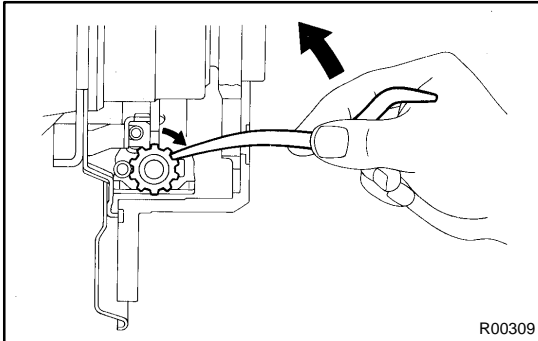

3. REMOVE DISC

HINT:

If the disc cannot be removed easily, turn the shoe adjuster until the wheel turns freely.

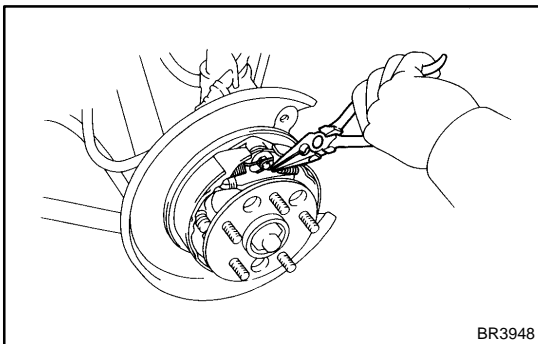

4. REMOVE SHOE RETURN SPRINGS

Using needle-nose pliers, remove the shoe return springs.

5. REMOVE FRONT SHOE ADJUSTER AND TENSION SPRING

- (a) Slide out the front shoe and remove the shoe adjuster.
 (b) Remove the shoe strut with the spring.
 (c) Remove the shoe hold-down spring cups, spring and pin.
 (d) Disconnect the tension spring and remove the front shoe.

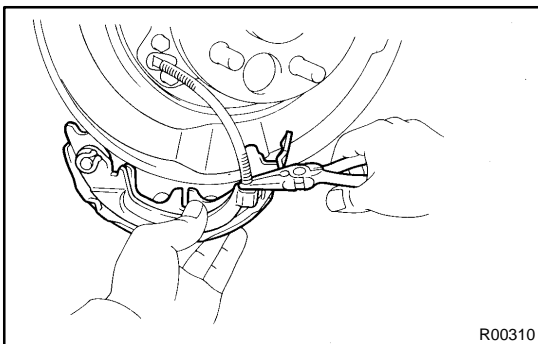

6. REMOVE REAR SHOE

- (a) Slide out the rear shoe.
 (b) Remove the tension spring from the rear shoe.
 (c) Remove the shoe hold-down spring cups, spring and pin.
 (d) Using needle-nose pliers, disconnect the parking brake cable from the parking brake shoe lever.

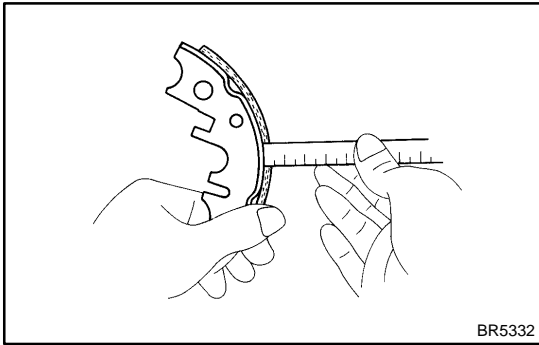

INSPECTION

1. INSPECT DISASSEMBLED PARTS

Inspect the disassembled parts for wear, rust or damage.

2. MEASURE BRAKE SHOE LINING THICKNESS

Using a ruler, measure the thickness of the shoe lining.

Standard thickness: 2.0 mm (0.079 in.)

Minimum thickness: 1.0 mm (0.039 in.)

If the lining thickness is at the minimum thickness or less, or if there is severe, uneven wear, replace the brake shoe.

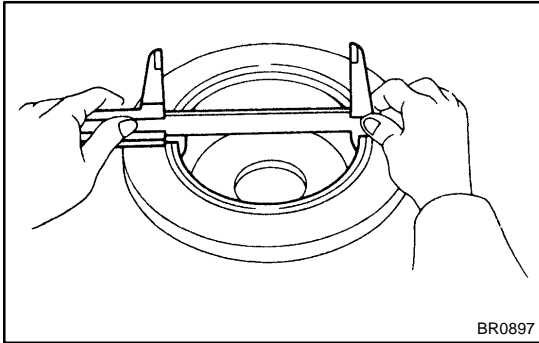

3. MEASURE DISC INSIDE DIAMETER

Using a vernier calipers, measure the inside diameter of the disc.

Standard inside diameter: 170 mm (6.69 in.)

Maximum inside diameter: 171 mm (6.73 in.)

Replace the disc if the inside diameter is at the maximum value or more. Replace the disc or grind it with a lathe if the disc is scored or is worn unevenly.

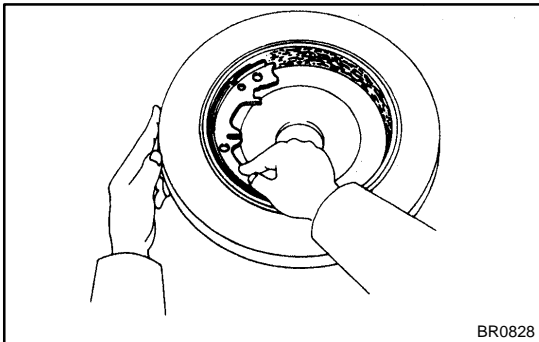

4. INSPECT PARKING BRAKE LINING AND DISC FOR PROPER CONTACT

Apply chalk to the inside surface of the disc, then grind down the brake shoe lining to fit. If the contact between the disc and the brake shoe lining is improper, repair it using a brake shoe grinder or replace the brake shoe assembly.

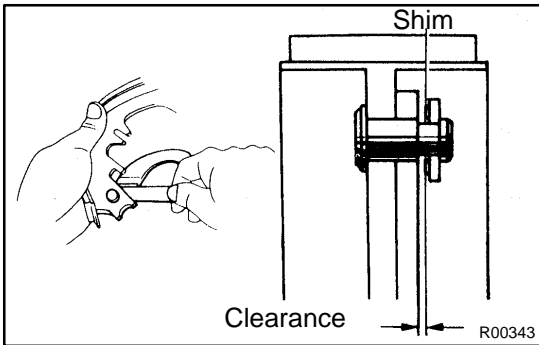

5. MEASURE CLEARANCE BETWEEN PARKING BRAKE SHOE AND LEVER

Using a feeler gauge, measure the clearance.

Standard clearance: Less than 0.35 mm (0.0138 in.)

If the clearance is not within the specification, replace the shim with one of the correct size.

Shim Thickness	Shim Thickness
0.3 mm (0.012 in.)	0.9 mm (0.035 in.)
0.6 mm (0.024 in.)	

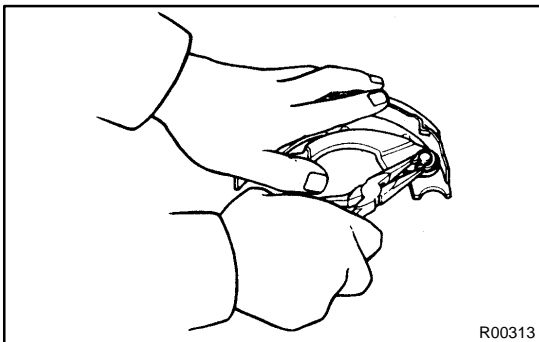

6. IF NECESSARY, REPLACE SHIM

- (a) Using a screwdriver, remove the C-washer and shim.
- (b) Remove the parking brake lever, and install the correct size shim.
- (c) Install the parking brake lever with a new C-washer.
- (d) Remeasure the clearance.

REASSEMBLY

Reassembly is in the reverse order of disassembly (See page BR-42).

NOTICE:

Apply high temperature grease to the parts indicated by the arrows (See page BR-41).

1. ADJUST PARKING BRAKE SHOE CLEARANCE

- (a) Temporarily install the hub nuts.
- (b) Remove the hole plug.
- (c) Turn the adjuster and expand the shoes until the disc locks.
- (d) Return the adjuster 8 notches.
- (e) Install the hole plug.

2. SETTLING PARKING BRAKE SHOES AND DISC

- (a) Depress the parking brake pedal with 147 N (15 kgf, 33 lbf)
- (b) Drive the vehicle at about 50 km/h (31 mph) on a safe, level and dry road for about 400 meters (0.25 mile) in this condition.
- (c) Repeat this procedure 2 or 3 times.

3. RECHECK AND ADJUST PARKING BRAKE PEDAL TRAVEL (See page BR-8)

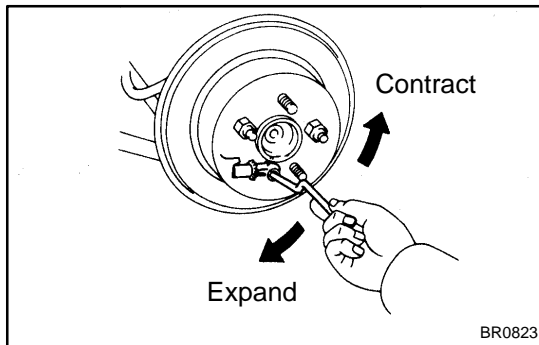

PROPORTIONING VALVE (P VALVE) ON-VEHICLE INSPECTION

BR073-04

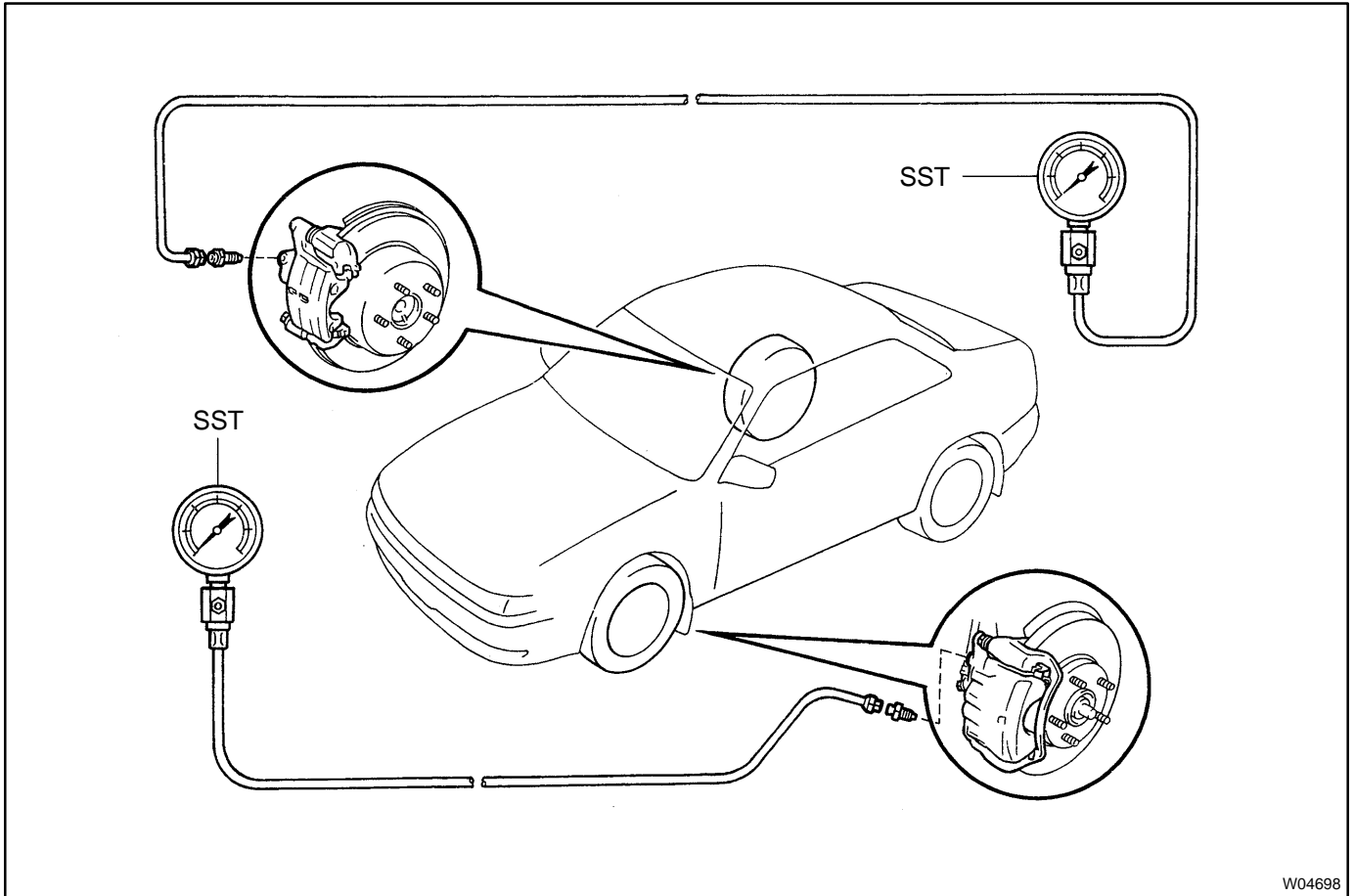

W04698

1. **INSTALL LSPV GAUGE (SST) AND BLEED AIR**
SST 09709-29018
2. **BLEED AIR FROM FLUID PRESSURE GAUGE**
3. **RAISE MASTER CYLINDER PRESSURE AND CHECK REAR CALIPER PRESSURE**

Master cylinder fluid pressure	Rear brake caliper fluid pressure
2,942 kPa (30 kgf/cm ² , 427 psi)	2,942 kPa (30 kgf/cm ² , 427 psi)
7,845 kPa (80 kgf/cm ² , 1,138 psi)	5,884 kPa (60 kgf/cm ² , 853 psi)

If the rear brake caliper pressure is incorrect, replace the P valve assembly.

4. **BLEED BRAKE SYSTEM (See page BR-4)**
5. **CHECK FOR LEAKS**

ABS ACTUATOR ON-VEHICLE INSPECTION

BR07B-01

HINT:

Using the ABS actuator checker (SST), check the operation of the actuator. If the actuator does not operate, check the operation of sub-wire harness G according to the instructions on pages DI-240 and DI-243. If the solenoid and/or pump motor relay are abnormal, replace the relay and inspect the actuator operation again.

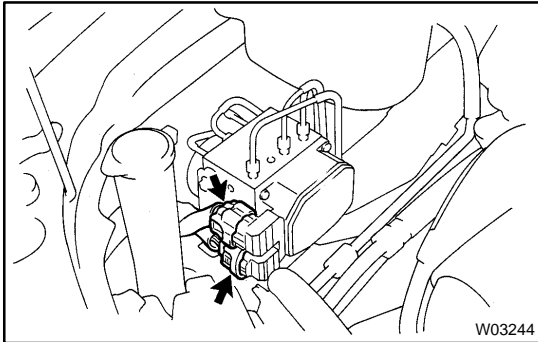

W03244

1. INSPECT BATTERY POSITIVE VOLTAGE

Battery positive voltage: 10 – 14 V

2. DISCONNECT CONNECTORS

Disconnect the 2 connectors from the actuator.

3. CONNECT ACTUATOR CHECKER (SST)

- (a) Connect the actuator checker (SST) to the actuator side wire harness via the sub-wire harness (SST), as shown. SST 09990-00150, 09990-00250, 09990-00300, 09990-00360
- (b) Connect the red cable of the checker to the battery positive (+) terminal and black cable to the negative (-) terminal. Connect the black cable of the sub-wire harness to the battery negative (-) terminal or body ground.

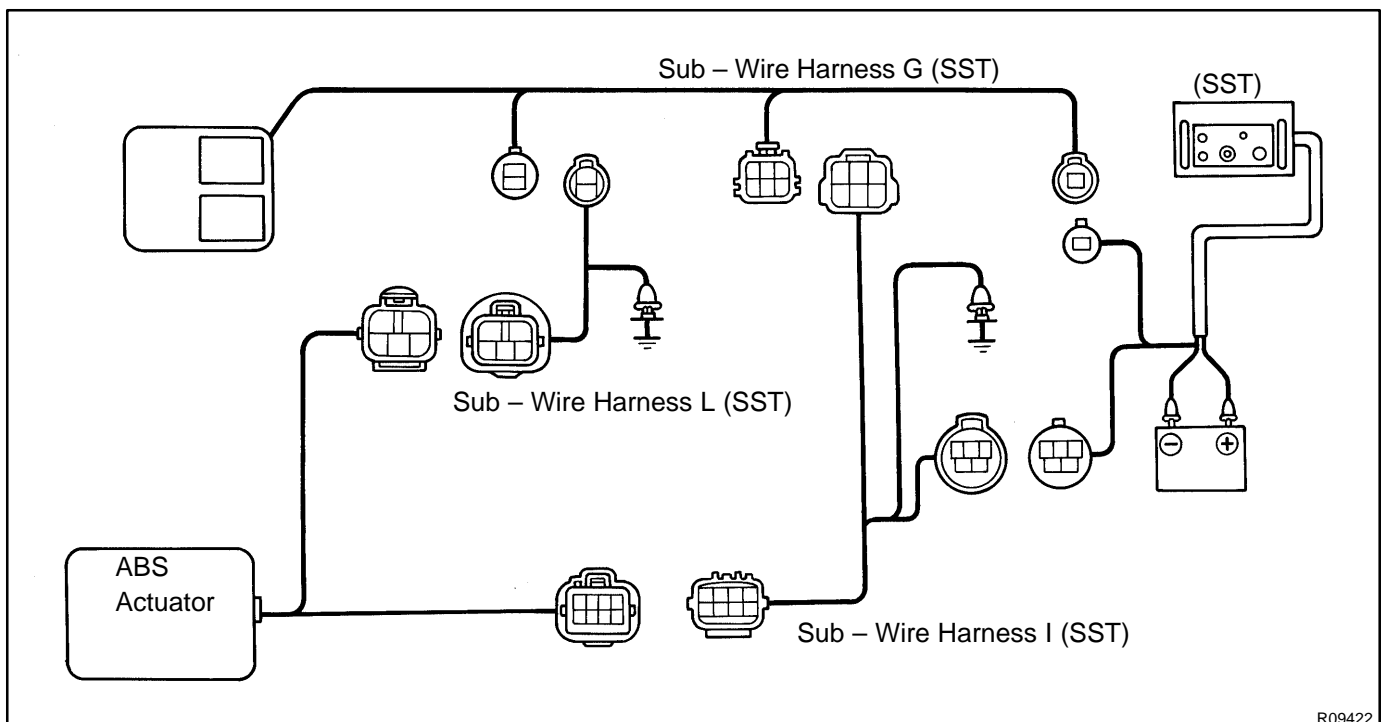

R09422

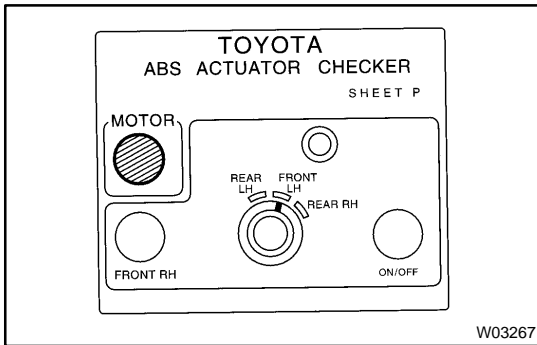

- (c) Place the "SHEET P" (SST) on the actuator checker.
SST 09990-00430
- 4. INSPECT BRAKE ACTUATOR OPERATION**
- (a) Start the engine, and run it at idle.
- (b) Turn the selector switch of the actuator checker to "FRONT LH" position.
- (c) Push and hold in the MOTOR switch for a few seconds.

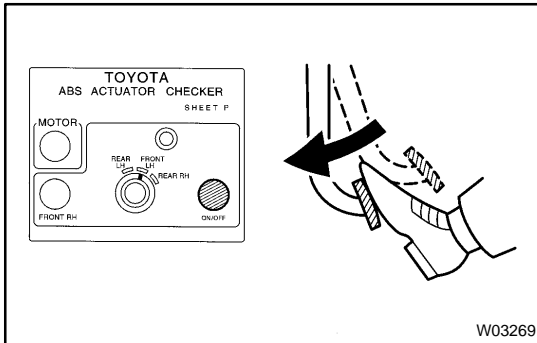

- (d) Depress the brake pedal and hold it until step (g) is completed.
- (e) Push the MAIN push switch, and check that the brake pedal does not go down.

NOTICE:

Do not keep the MAIN push switch pushed down for more than 10 seconds.

- (f) Release the switch, and check that the pedal goes down.

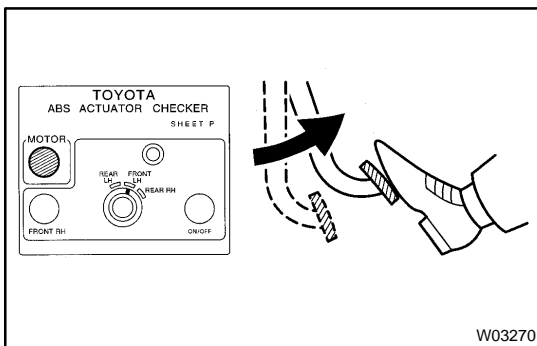

- (g) Push and hold in the MOTOR switch for a few seconds, and check that the pedal returns.
- (h) Release the brake pedal.

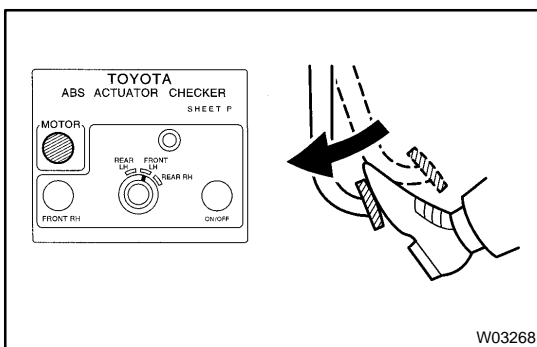

- (i) Push and hold in the MOTOR switch for a few seconds.
- (j) Depress the brake pedal and hold it for about 15 seconds. As you hold the pedal down, push the MOTOR switch for a few seconds. Check that the brake pedal does not pulsate.
- (k) Release the brake pedal.

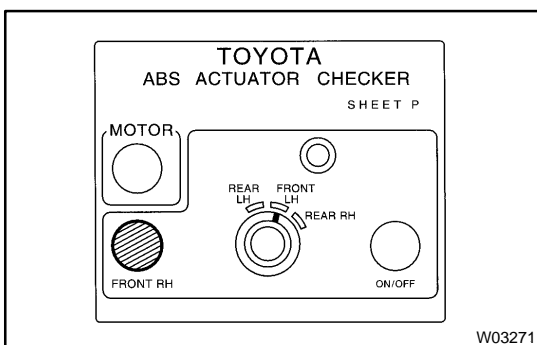

- (l) Turn the selector switch to "REAR RH" position.
- (m) Repeat (c) to (j), checking the actuator operation similarly.
- (n) Similarly, inspect "REAR LH" and "FRONT RH" position.

HINT:

When inspecting "FRONT RH" position, push the FRONT RH switch instead of the MAIN push switch, and you can inspect in any selector switch position.

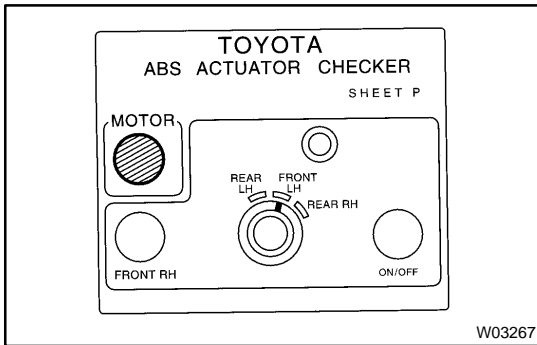

- (o) Push and hold in the MOTOR switch for a few seconds.
- (p) Stop the engine.

5. DISCONNECT ACTUATOR CHECKER (SST) FROM ACTUATOR

Remove the "SHEET P" (SST) and disconnect the actuator checker (SST) and sub-wire harness (SST) from the actuator.

SST 09990-00150, 09990-00250, 09990-00300,
09990-00360, 09990-00430

6. CONNECT CONNECTORS

Connect the 2 connectors to the actuator.

7. CLEAR DTC (See page [DI-232](#))

COMPONENTS

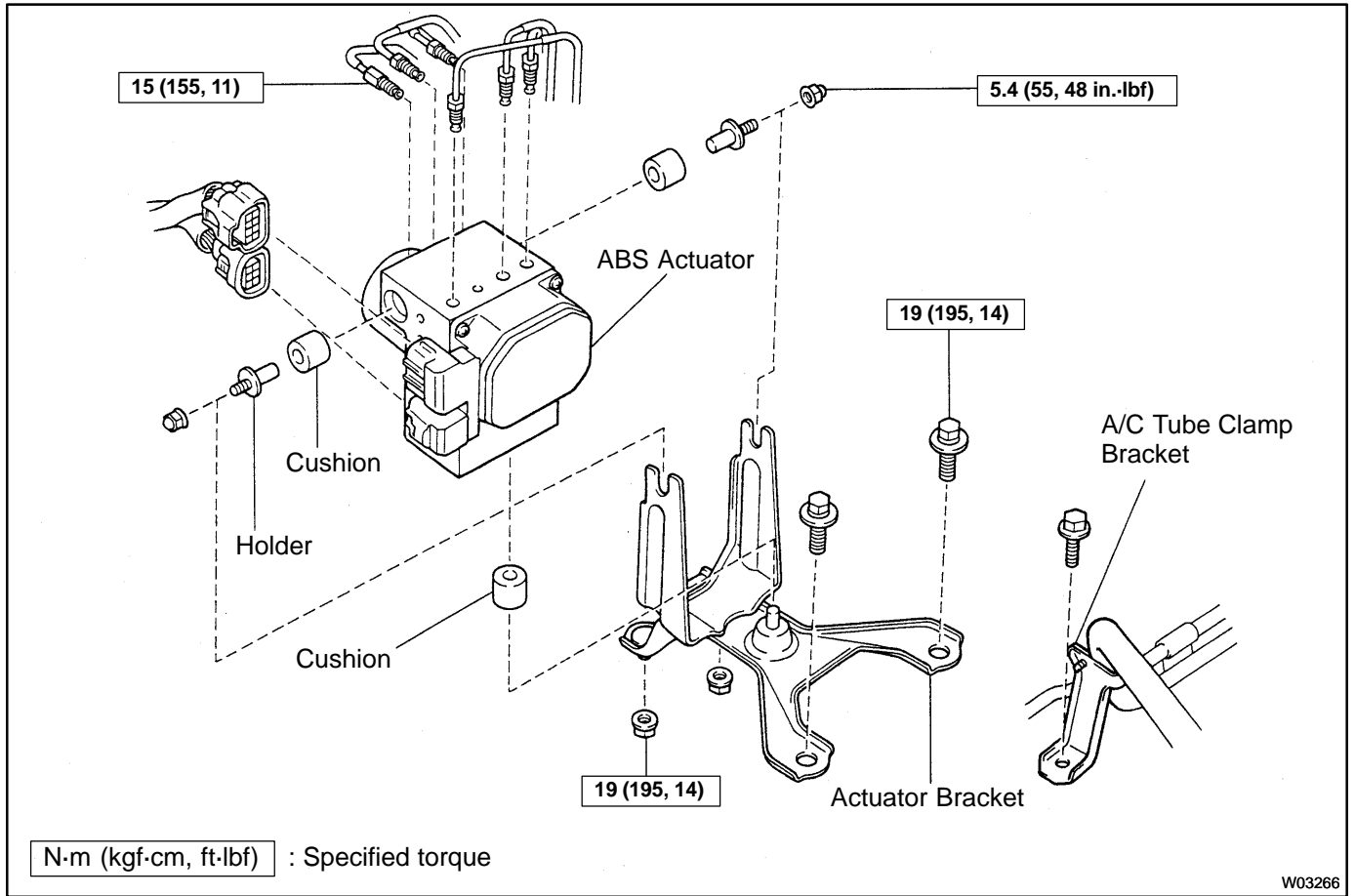

W03266

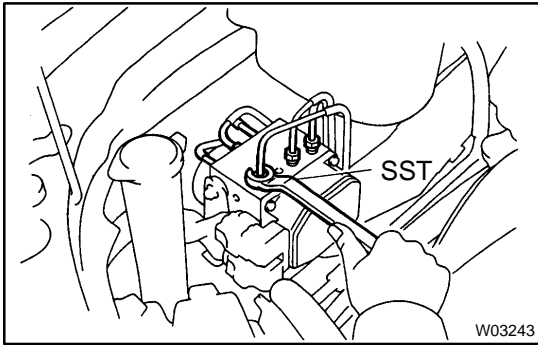

REMOVAL

1. REMOVE RIGHT FRONT FENDER LINER
2. REMOVE A/C TUBE CLAMP BRACKET BOLT
3. DISCONNECT BRAKE LINES

Using SST, disconnect the 6 brake lines from the ABS actuator.

SST 09751-36011

Torque: 15 N·m (155 kgf·cm, 11 ft·lbf)

4. REMOVE ABS ACTUATOR ASSEMBLY

- (a) Disconnect the 2 connectors.
- (b) Remove the 2 bolts, 2 nuts and ABS actuator assembly.

Torque: 19 N·m (195 kgf·cm, 14 ft·lbf)

5. REMOVE ABS ACTUATOR

- (a) Remove the 2 nuts and ABS actuator from actuator bracket.

Torque: 5.4 N·m (55 kgf·cm, 48 in.-lbf)

- (b) Remove the 2 holders and 3 cushions from the ABS actuator.

INSTALLATION

Installation is in the reverse order of removal (See page [BR-50](#)).

1. AFTER INSTALLATION, FILL BRAKE RESERVOIR WITH BRAKE FLUID AND BLEED BRAKE SYSTEM (See page [BR-4](#))
2. CHECK FOR LEAKS

ABS & TRAC ACTUATOR ON-VEHICLE INSPECTION

BR07A-02

HINT:

Using the ABS actuator checker (SST), check the operation of the actuator. If the actuator does not operate, check the operation of sub-wire harness G according to the instructions on pages DI-283 and DI-286. If the solenoid and/or pump motor relay are abnormal, replace the relay and inspect the actuator operation again.

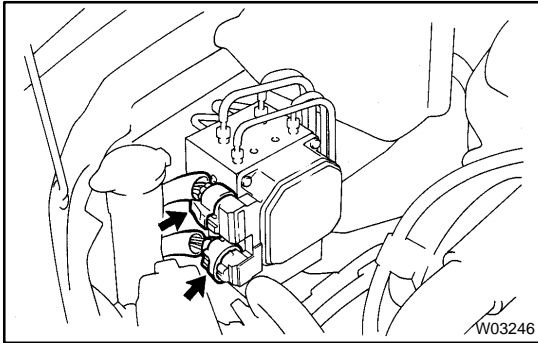

1. INSPECT BATTERY POSITIVE VOLTAGE

Battery positive voltage: 10 – 14 V

2. DISCONNECT CONNECTORS

Disconnect the 2 connectors from the actuator.

3. CONNECT ACTUATOR CHECKER (SST)

- (a) Connect the actuator checker (SST) to the actuator side wire harness via the sub-wire harness (SST), as shown. SST 09990-00150, 09990-00250, 09990-00360, 09990-00450
- (b) Connect the red cable of the checker to the battery positive (+) terminal and black cable to the negative (-) terminal. Connect the black cable of the sub-wire harness to the battery negative (-) terminal or body ground.

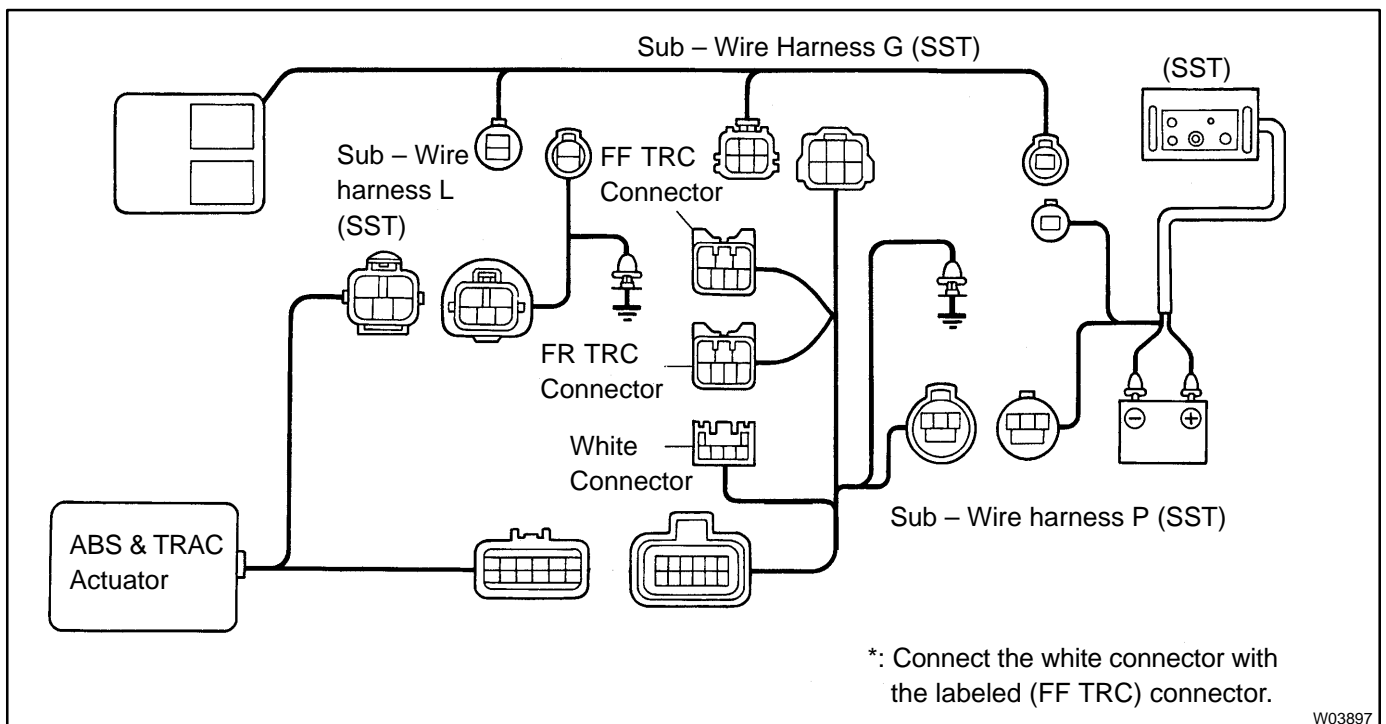

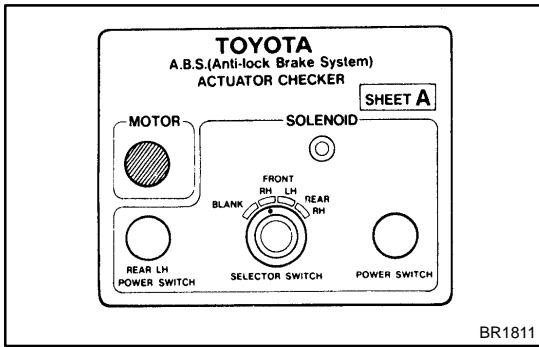

- (c) Place the "SHEET A" (SST) on the actuator checker. SST 09990-00163
- 4. INSPECT BRAKE ACTUATOR OPERATION**
- (a) Start the engine, and run it at idle.
- (b) Turn the selector switch of the actuator checker to "FRONT RH" position.
- (c) Push and hold in the MOTOR switch for a few seconds.

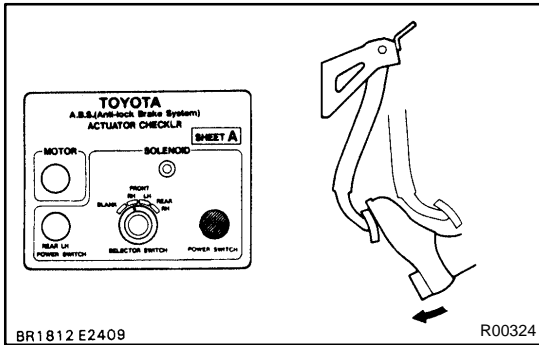

- (d) Depress the brake pedal and hold it until step (g) is completed.
- (e) Push the POWER SWITCH, and check that the brake pedal does not go down.

NOTICE:

Do not keep the POWER SWITCH pushed down for more than 10 seconds.

- (f) Release the switch, and check that the pedal goes down.

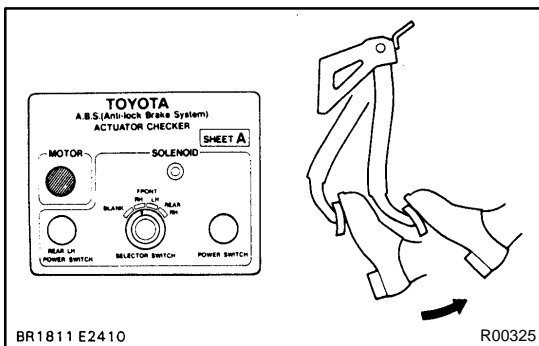

- (g) Push and hold in the MOTOR switch for a few seconds, and check that the pedal returns.
- (h) Release the brake pedal.

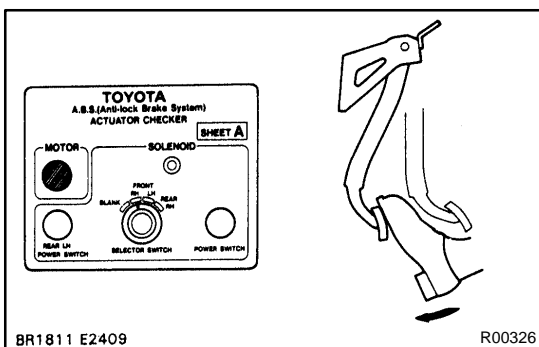

- (i) Push and hold in the MOTOR switch for a few seconds.
- (j) Depress the brake pedal and hold it for about 15 seconds. As you hold the pedal down, push the MOTOR switch for a few seconds. Check that the brake pedal does not pulsate.
- (k) Release the brake pedal.

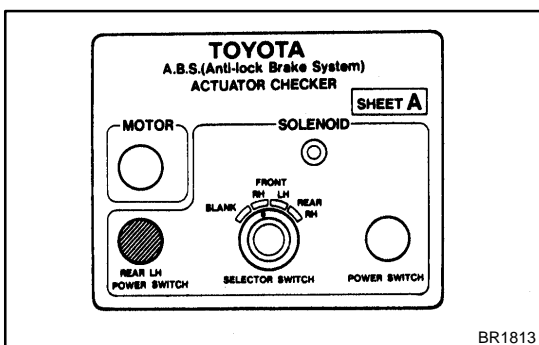

- (l) Turn the selector switch to "FRONT LH" position.
- (m) Repeat (c) to (j), checking the actuator operation similarly.
- (n) Similarly, inspect "REAR RH" and "REAR LH" position.

HINT:

When inspecting "REAR LH" position, push the REAR LH switch instead of the POWER SWITCH, and you can inspect in any selector switch position.

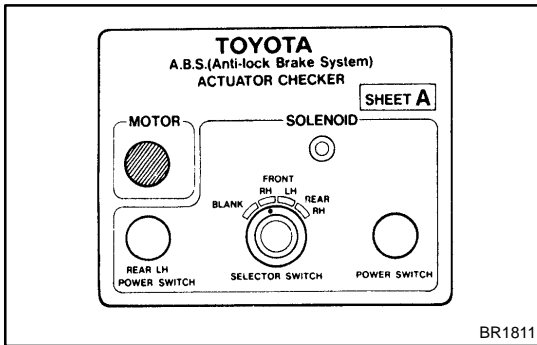

- (o) Push and hold in the MOTOR switch for a few seconds.
- (p) Stop the engine.

5. DISCONNECT ACTUATOR CHECKER (SST) FROM ACTUATOR

Remove the "SHEET A" (SST) and disconnect the actuator checker (SST) and sub-wire harness (SST) from the actuator.

SST 09990-00150, 09990-00163, 09990-00250,
09990-00360, 09990-00450

6. CONNECT CONNECTORS

Connect the 2 connectors to the actuator.

7. CLEAR DTC (See page DI-273)

COMPONENTS

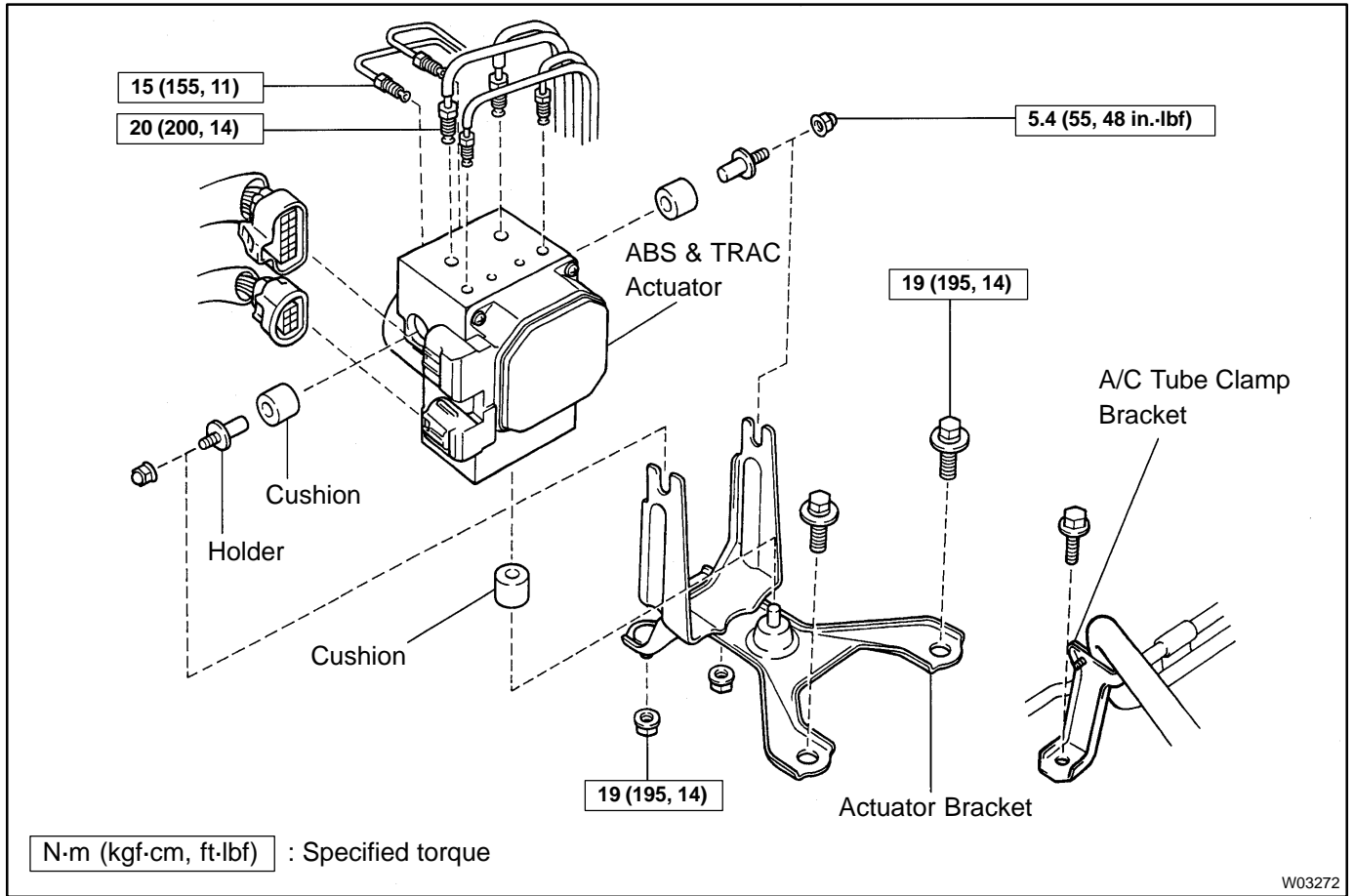

W03272

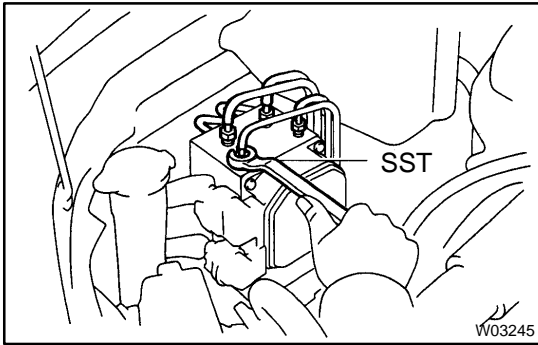

REMOVAL

1. REMOVE RIGHT FRONT FENDER LINER
2. REMOVE A/C TUBE CLAMP BRACKET BOLT
3. DISCONNECT BRAKE LINES

Using SST, disconnect the 6 brake lines from the ABS & TRAC actuator.

SST 09751-36011

Torque:

10 mm nut 15 N·m (155 kgf·cm, 11 ft·lbf)

12 mm nut 20 N·m (200 kgf·cm, 14 ft·lbf)

4. REMOVE ABS & TRAC ACTUATOR ASSEMBLY
 - (a) Disconnect the 2 connectors.
 - (b) Remove the 2 bolts, 2 nuts and ABS & TRAC actuator assembly.

Torque: 19 N·m (195 kgf·cm, 14 ft·lbf)

5. REMOVE ABS & TRAC ACTUATOR
 - (a) Remove the 2 nuts and ABS & TRAC actuator from actuator bracket.

Torque: 5.4 N·m (55 kgf·cm, 48 in.-lbf)

- (b) Remove the 2 holders and 3 cushions from the ABS & TRAC actuator.

INSTALLATION

Installation is in the reverse order of removal (See page [BR-56](#)).

1. AFTER INSTALLATION, FILL BRAKE RESERVOIR WITH BRAKE FLUID AND BLEED BRAKE SYSTEM (See page [BR-4](#))
2. CHECK FOR LEAKS

FRONT SPEED SENSOR COMPONENTS

BR07C-04

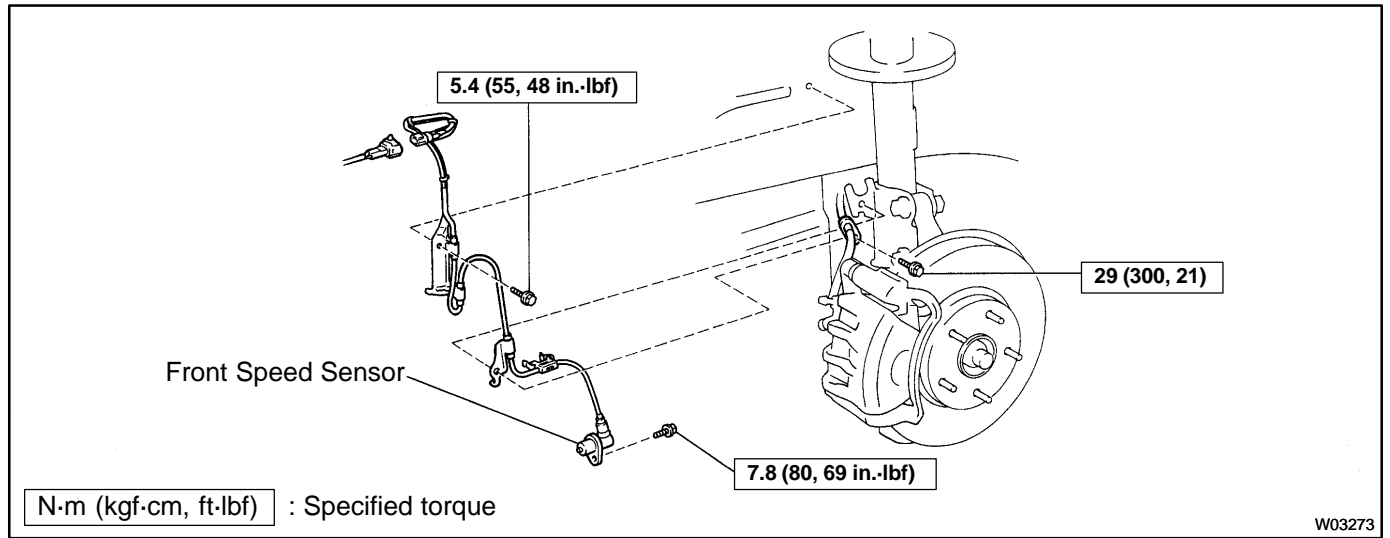

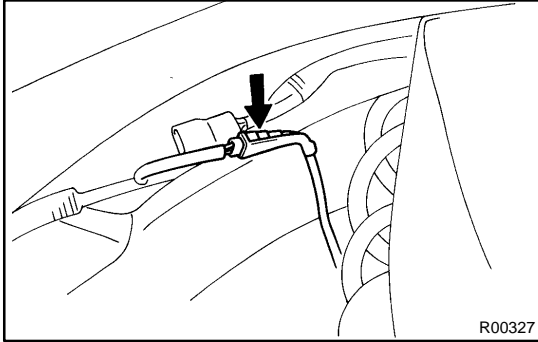

REMOVAL

1. DISCONNECT SPEED SENSOR CONNECTOR

- (a) Remove the fender liner.
- (b) Disconnect the speed sensor connector.

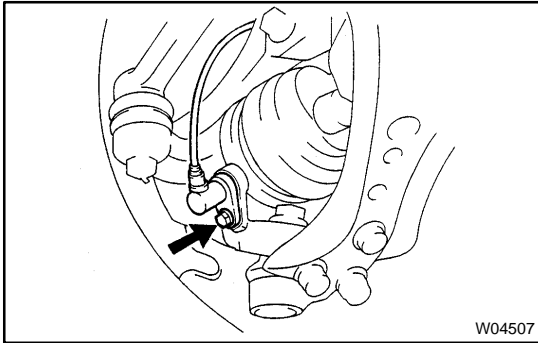

2. REMOVE SPEED SENSOR

- (a) Remove the bolt, flexible hose and speed sensor harness clamp from the shock absorber.

Torque: 29 N·m (300 kgf·cm, 21 ft·lbf)

- (b) Remove the resin clip and clamp bolt holding the sensor harness to the body.

Torque: 5.4 N·m (55 kgf·cm, 48 in.-lbf)

- (c) Remove the speed sensor from the steering knuckle.

Torque: 7.8 N·m (80 kgf·cm, 69 in.-lbf)

INSTALLATION

Installation is in the reverse order of removal (See page [BR-59](#)).

AFTER INSTALLATION, CHECK SPEED SENSOR SIGNAL (See page [DI-232](#) or [DI-273](#))

REAR SPEED SENSOR COMPONENTS

BR07F-04

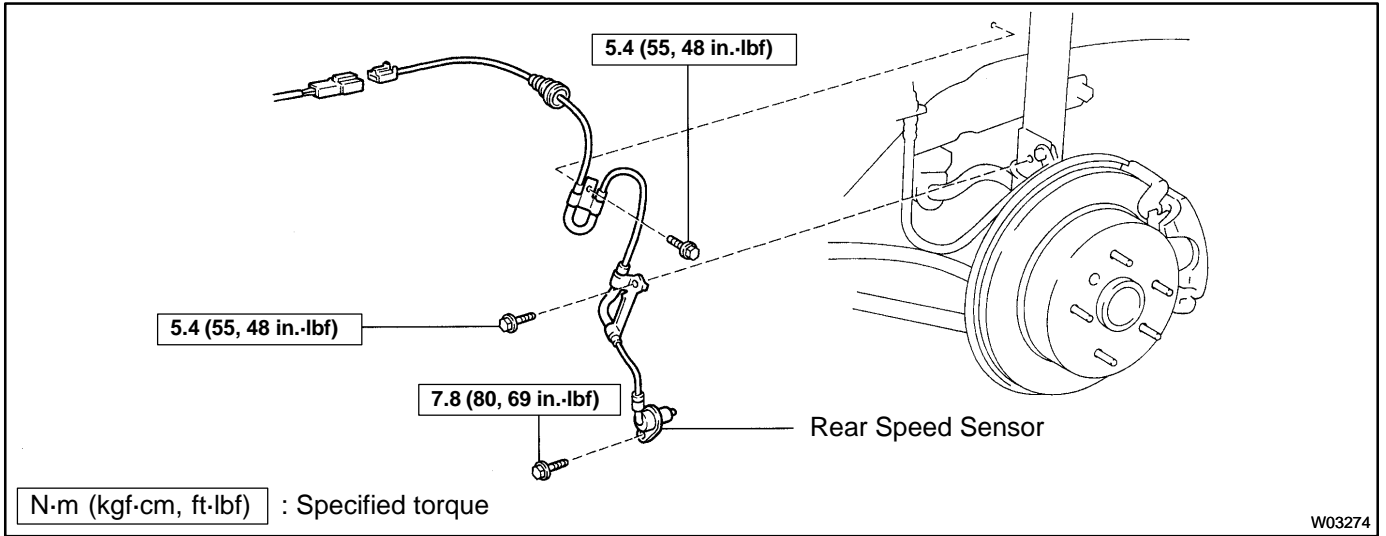

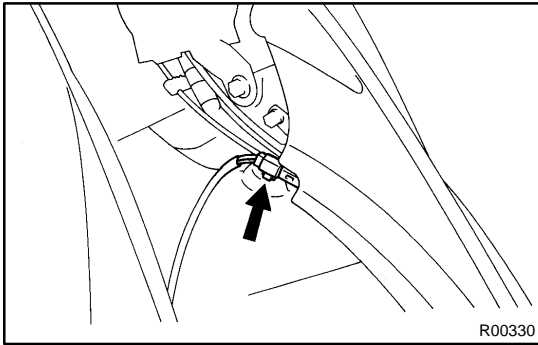

REMOVAL

1. DISCONNECT SPEED SENSOR CONNECTOR

- (a) Remove the seat cushion and seatback.
- (b) Disconnect the speed sensor connector, and pull out the sensor wire harness with the grommet.

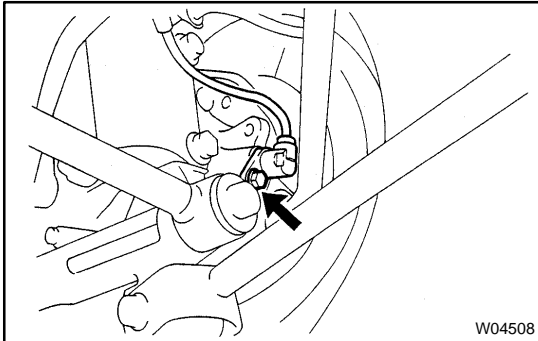

2. REMOVE SPEED SENSOR

- (a) Remove the 2 clamp bolts holding the sensor wire harness to the body and shock absorber.
Torque: 5.4 N·m (55 kgf·cm, 48 in.-lbf)
- (b) Remove the speed sensor from the axle carrier.
Torque: 7.8 N·m (80 kgf·cm, 69 in.-lbf)

INSTALLATION

Installation is in the reverse order of removal (See page [BR-62](#)).

AFTER INSTALLATION, CHECK SPEED SENSOR SIGNAL (See page [DI-232](#) or [DI-273](#))